

# OWNER'S MANUAL



Original instructions

EN

# MFS 25D MFS 30D

OB No.003-11171-0BB1

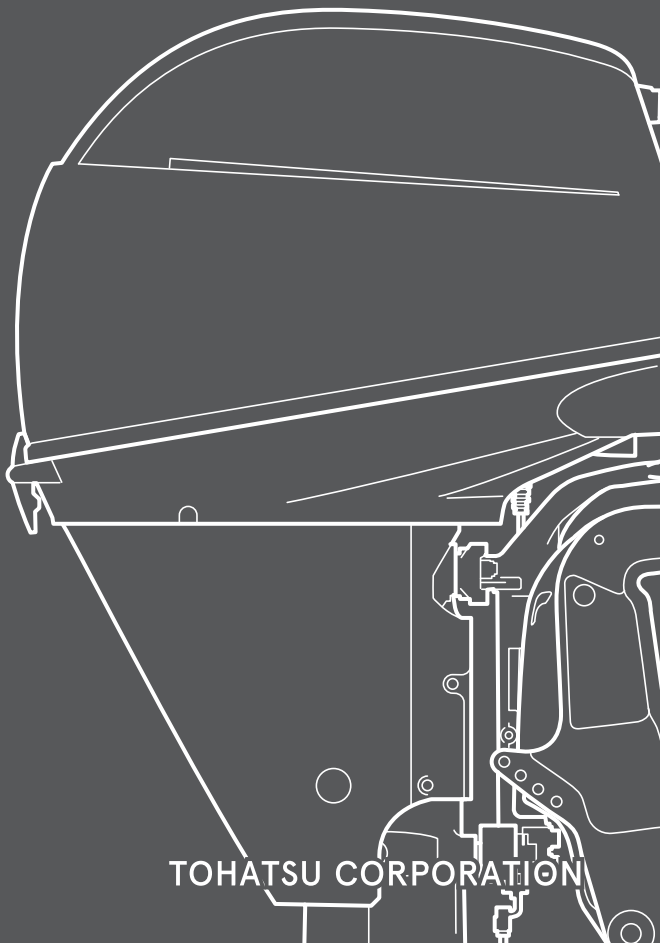

BACKS  
YOU  
UP™

TOHATSU CORPORATION

ENOM00001-0

 **READ THIS MANUAL BEFORE USING THE OUTBOARD MOTOR. FAILURE TO FOLLOW THE INSTRUCTIONS AND SAFETY PRECAUTIONS IN THIS MANUAL CAN RESULT IN SERIOUS INJURY OR DEATH. KEEP THIS MANUAL IN A SAFE LOCATION FOR FUTURE REFERENCE.**

Copyright © 2022 Tohatsu Corporation. All rights reserved. No part of this manual may be reproduced or transmitted in any form or by any means without the express written permission of Tohatsu Corporation.

# YOUR TOHATSU OUTBOARD MOTOR

ENOM00006-2

## **To You, Our Customer**

Congratulations on your purchase of the TOHATSU outboard motor. You are now the proud owner of an excellent outboard motor that will serve you for many years to come. This owner's manual contains important safety, operational and maintenance information.

The efficiency and longevity of your outboard motor will depend heavily on your operating methods and periodic maintenance. Failure to operate and maintain your outboard motor according to the instruction in this owner's manual may void the limited warranty, as well as reduce the efficiency and reliability of the outboard motor.

Any person operating TOHATSU outboard motor must carefully read and fully understand the entire contents of this manual prior to operation. For safety, follow all safety warnings contained within the owner's manual and the labels applied to your outboard motor. You should keep this owner's manual where accessible while operating your outboard motor. If the outboard motor is resold, make sure the manual is passed on to the next owner. In case you encounter any problems, please contact an authorized TOHATSU service shop or dealer for assistance.

Tohatsu Corporation reserves the right to change, modify, add, or remove a part or whole of the owner's manual without prior notice and incurring any obligations.

We are excited to take a part in your boating adventures and wish for your great and safe boating experience.

**TOHATSU CORPORATION**

ENOM00002-0

## **OWNER REGISTRATION AND IDENTIFICATION**

Upon purchasing this product, be sure that the WARRANTY CARD is correctly and completely filled out and mailed to the addressee noted there on. This WARRANTY CARD identifies you as the legal owner of the product and serves as your warranty registration.

TO THE EXTENT PERMITTED BY APPLICABLE LAW, YOUR OUTBOARD MOTOR WILL NOT BE COVERED BY THE APPLICABLE LIMITED WARRANTY, IF THIS PROCEDURE IS NOT FOLLOWED.

ENOM00003-1

**PRE-DELIVERY INSPECTION**

Make sure Pre-delivery inspection has been properly done by authorized TOHATSU dealer before operating your outboard motor.

ENOM00005-1

**Serial Number**

Your outboard motor has a unique serial number. The serial number is identification of outboard motor and is located on the outboard motor as shown in the figures below. The serial number is required for warranty registration, filing a warranty claim as well as making technical inquiries and may be required for other occasions. Therefore, please write down the serial number and date of purchase in the space below.

**Serial Number:**

MF/E model
------------

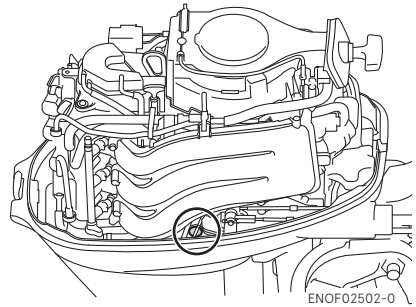
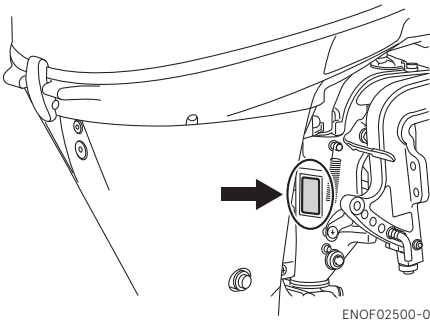

ET model
----------

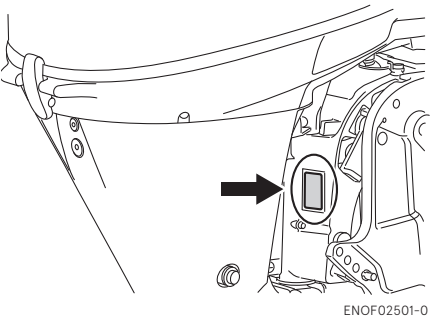

Serial Number:

Date of purchase

ENOM00007-0

**NOTICE: DANGER/WARNING/CAUTION/Note**

Before installing, operating or otherwise handling your outboard motor, be sure to thoroughly read and understand this Owner's Manual and carefully follow all of the instructions. Of particular importance is information preceded by the words "DANGER," "WARNING," "CAUTION," and "Note." Always pay special attention to such information to ensure safe operation of the outboard motor at all times.

ENOW00001-0

 **DANGER**

**Failure to observe will result in severe personal injury or death, and possibly property damage.**

ENOW00002-0

 **WARNING**

**Failure to observe could result in severe personal injury or death, or property damage.**

ENOW00003-0

 **CAUTION**

**Failure to observe could result in personal injury or property damage.**

ENON00001-0

**Note**

This instruction provides special information to facilitate the use or maintenance of the outboard motor or to clarify important points.



# CONTENTS

1.	GENERAL SAFETY INFORMATION . . . . .	10
2.	SPECIFICATIONS . . . . .	12
3.	PARTS NAME . . . . .	15
4.	LABEL LOCATIONS . . . . .	21
5.	INSTALLATION . . . . .	25
	1. Mounting the outboard motor on boat . . . . .	25
	2. Battery installation . . . . .	28
	3. TOCS (Tohatsu Onboard Communication System) installation . . . . .	29
6.	PRE-OPERATING PREPARATIONS . . . . .	30
	1. Fuel handling . . . . .	30
	2. Fuel filling . . . . .	31
	3. Engine oil filling . . . . .	32
	4. Break-In . . . . .	34
	5. Warning system . . . . .	35
7.	ENGINE OPERATION . . . . .	38
	Before starting . . . . .	38
	1. Fuel feeding . . . . .	38
	2. Starting the engine . . . . .	39
	3. Warming up the engine . . . . .	46
	4. Forward, reverse, and acceleration . . . . .	47
	5. Stopping the engine . . . . .	50
	6. Steering . . . . .	53
	7. Trim angle . . . . .	53
	8. Tilt up and down . . . . .	55
	9. Shallow water operation . . . . .	58
8.	REMOVING AND CARRYING THE OUTBOARD MOTOR . . . . .	60
	1. Removing the outboard motor . . . . .	60
	2. Carrying the outboard motor . . . . .	60
	3. Trailering . . . . .	61
9.	ADJUSTMENT . . . . .	63
	1. Steering friction . . . . .	63
	2. Throttle grip friction . . . . .	63
	3. Remote control lever friction . . . . .	63
	4. Trim tab adjustment . . . . .	64
	5. Multi-function tiller handle angle adjustment . . . . .	65
10.	INSPECTION AND MAINTENANCE . . . . .	66
	1. Daily Inspection . . . . .	67
	2. Periodic Inspection . . . . .	73
	3. Off-season storage . . . . .	86
	4. Pre-season check . . . . .	89
	5. Submerged outboard motor . . . . .	89
	6. Cold weather precautions . . . . .	90
	7. Striking underwater object . . . . .	90

8. Operation with multiple outboard motors . . . . .	90
11. TROUBLESHOOTING . . . . .	91
12. ACCESSORIES KIT . . . . .	94
13. PROPELLER TABLE . . . . .	95



# INDEX

<b>1. GENERAL SAFETY INFORMATION</b>	<b>1</b>
.....	
<b>2. SPECIFICATIONS</b>	<b>2</b>
.....	
<b>3. PARTS NAME</b>	<b>3</b>
.....	
<b>4. LABEL LOCATIONS</b>	<b>4</b>
.....	
<b>5. INSTALLATION</b>	<b>5</b>
.....	
<b>6. PRE-OPERATING PREPARATIONS</b>	<b>6</b>
.....	
<b>7. ENGINE OPERATION</b>	<b>7</b>
.....	
<b>8. REMOVING AND CARRYING THE OUTBOARD MOTOR</b>	<b>8</b>
.....	
<b>9. ADJUSTMENT</b>	<b>9</b>
.....	
<b>10. INSPECTION AND MAINTENANCE</b>	<b>10</b>
.....	
<b>11. TROUBLESHOOTING</b>	<b>11</b>
.....	
<b>12. ACCESSORIES KIT</b>	<b>12</b>
.....	
<b>13. PROPELLER TABLE</b>	<b>13</b>
.....	

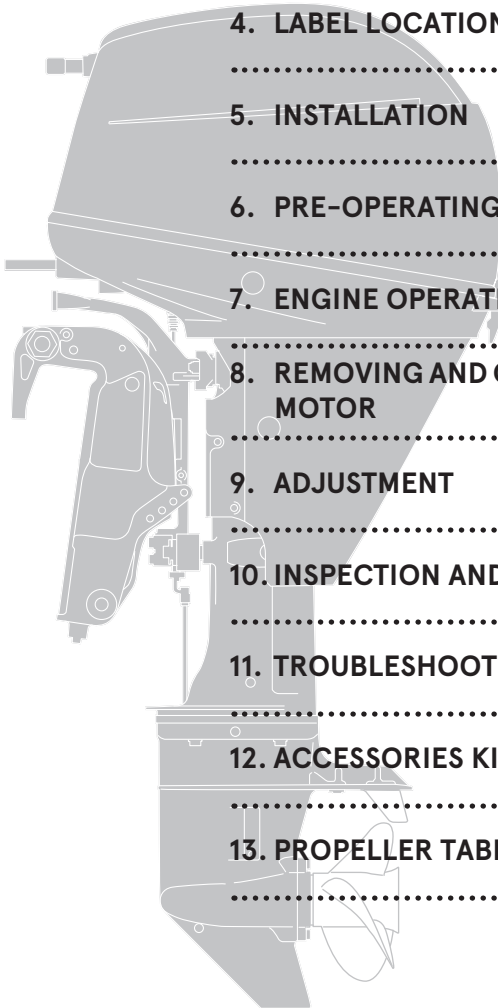

# GENERAL SAFETY INFORMATION

## 1

ENOM00009-1

### SAFE OPERATION OF BOAT

As the operator/driver of a boat, you are responsible for the safety of those aboard and those in other boats around yours, and for following local boating regulations. You should be thoroughly knowledgeable on how to correctly operate the boat, outboard motor, and accessories. To learn about the correct operation and maintenance of the outboard motor, please read through this manual carefully.

It is very difficult for a person in the water to take evasive action should he or she see a power boat heading in his/her direction, even at a slow speed.

Therefore, when your boat is in the immediate vicinity of people in the water, the outboard motor must be shifted to neutral and shut off.

ENOW00005-0

### WARNING

**SERIOUS INJURY IS LIKELY IF A PERSON IN THE WATER MAKES CONTACT WITH A MOVING BOAT, GEAR HOUSING, PROPELLER, OR ANY SOLID DEVICE RIGIDLY ATTACHED TO A BOAT OR GEAR HOUSING.**

ENOM00247-1

### STOP SWITCH LANYARD

The engine can be stopped by pulling out the stop switch lock from the stop switch. The stop switch lanyard is the coiled red cord with the stop switch lock on one end and a metal clip on the other end. With attaching the stop switch lanyard to the operator's body part or operator's personal flotation device (PFD), the engine will stop when the stop switch lanyard is being stretched and pulled out the lock from the switch if the operator accidentally falls overboard or leaves from operator's position. This function may prevent losing control of the boat and minimize or prevent risk of collision with other boats, people and other objects. It is operator's responsibility to use the stop switch lanyard.

ENOW00004-1

### WARNING

**Accidental activation of the Stop Switch (such as the tether being pulled out in heavy seas) could cause passengers to lose their balance and even fall overboard, or it could result in loss of power in heavy seas, strong currents, or high winds. Loss of control while mooring is another potential hazard.**

**To minimize accidental activation of the Stop Switch, the 500 mm (20 inch.) stop switch lanyard is coiled and can be extended to a full 1300 mm (51 inch.).**

ENOM00800-A

**PERSONAL FLOTATION DEVICE**

As the operator/driver and passenger of a boat, you are responsible to wear a PFD (Personal Flotation Device) while on the boat.

ENOM00010-1

**SERVICING , REPLACEMENT PARTS & LUBRICANTS**

We recommend that only an authorized service shop perform service or maintenance on your outboard motor. Be sure to use genuine parts, genuine lubricants, or recommended lubricants. Be aware that the installation and use of parts not approved by Tohatsu Corporation will void warranty and may lead to unsafe operating conditions.

ENOM00011-1

**MAINTENANCE**

As the owner of the outboard motor, you should be acquainted with correct maintenance procedures following by maintenance section of this manual (See page 66). It is the operator's responsibility to perform all safety inspections, proper lubrication and to follow all maintenance instructions for safe operation. You should take the engine to an authorized dealer or service shop for periodic inspection at the prescribed intervals. Correct periodic maintenance and proper care of outboard motor will reduce the chance of problems, limit overall operating expenses and contribute to longevity of your outboard motor.

**Carbon Monoxide Poisoning Hazard**

Exhaust gas contains carbon monoxide, a colorless and odorless gas which can be fatal if inhaled for any length of time.

Never start or operate the engine indoors or in any space which is not well ventilated.

**Gasoline**

Gasoline and its vapors are very flammable and can be explosive. Use extreme care when handling gasoline. You should be thoroughly knowledgeable on how to correctly handle gasoline by reading this manual.

# SPECIFICATIONS

ENOM00810-B

## MODEL FEATURE

2

Model		MFS25D		MFS30D		
Type		MF	ET	MF	E	ET
Transom heights	S	●	—	●	●	●
	L	●	●	●	●	●
Basic Tiller Handle		●	(●)	●	(●)	(●)
Multi-function tiller handle		—	(●)	—	(●)	(●)
Remote Control		—	(●)	—	(●)	(●)
Power Tilt		—	●	—	(●)	●
Gas-assisted tilt		—	—	—	—	—
Manual tilt		●	—	●	●	—

(●) These models can be purchased with remote rigging kit or multi function tiller handle.

ENOM00811-A

## MODEL NAME EXAMPLE

F 30D ETL

F	30	D	E	T	L
Model description	Horse power	Product generation	Starter system	Tilt system	Shaft length
F= Four stroke	—	A and up	E= Electrical start M= Manual start	T= Power tilt G= Gas assist Blank= Manual tilt	S= Short 15 in L= Long 20 in UL= Ultra long 25 in

ENOM00013-0

2

**MF, ET (EFT), ET (EHT), ET (EPT)**

Item	Model	MFS 25/30D				
		MF	ET (EFT)	ET (EHT)	ET (EHT)	ET (EPT)
		with basic tiller handle		with multi-function tiller handle		with RC
Overall Length	mm (in)	1113 (43.80)		1360 (53.55)		732 (28.80)
Overall Width	mm (in)	401 (15.80)		389 (15.30)		
Overall Height	mm (in)	S : 1216 (47.85) L : 1343 (52.85)				
Transom Height	mm (in)	S : 425 (16.75) L : 552 (21.75)				
Weight*1	S kg (lb)	58.0 (128)	69.0 (152) (MFS30D)	71.0 (156) (MFS30D)		67.0 (148) (MFS30D)
	L kg (lb)	58.5 (129)	69.5 (153)	71.5 (157)		67.5 (149)
Engine Type		4 stroke				
Number of Cylinder		3				
Piston Displacement	cm <sup>3</sup> (cu.in.)	500 (30.50)				
Bore x Stroke	mm (in)	61 x 57 (2.40) x (2.25)				
Max. Output	kW (PS)	18.4 (25) 22.1 (30)				
Max. Operating Range	min <sup>-1</sup> (rpm)	25D : 5000 - 6000, 30D : 5500 - 6500				
Idle Speed	min <sup>-1</sup> (rpm)	850				
Exhaust System		Through-hub exhaust				
Lubrication System		Wet sump				
Cooling System		Water cooling				
Starting System		Electric and Recoil				
Ignition System		Flywheel Magneto CD ignition				
Alternator		12V - 17.5A				
Steering Angle	Degree	76				
Trim Position		6	4			
Trim Up Angle	Degree	72	74			
Gear Shift		Dog clutch (F-N-R)				
Gear Reduction Ratio		26 : 12 (2.17)				
Operator Sound Pressure (ICOMIA 39/94 Rev.1) dB (A)		83.2				
Hand Vibration Level (ICOMIA 38/94 Rev.1) m/s <sup>2</sup>		4				-

Remark: Specifications are subject to change without notice.

\*1 With propeller

Tohatsu outboard is power rated in accordance with ISO8665 (propeller shaft output).

## Service data

Item	Model	MFS 25/30D				
		MF	ET (EFT)	ET (EHT)	ET (EHT)	ET (EPT)
		with basic tiller handle		with multi-function tiller handle		with RC
Fuel	Grade	Unleaded Regular Gasoline : R+M/2: 87 or higher RON: 91 or higher				
	L (US gal)	25 (6.60)				
Engine Oil	Grade	API: SH, SJ, SL, SAE: 10W-30, 10W-40				
	mL (US/Imp.qt)	1500 (1.6/1.3) without oil filter replacement				
		1700 (1.8/1.5) with oil filter replacement				
Gear Oil	Grade	API:GL-5, SAE:80-90				
	mL (US/Imp.oz)	460 (15.6/16.2)				
PTT Fluid		-	ATF (Automatic Transmission Fluid) Dexron III			
Battery (minimum requirements)		64Ah/5HR (70Ah/20HR, 512CCA)				
Spark Plug		NGK DCPR6E equivalent				
Spark Plug Gap	mm (in)	0.8-0.9 (0.031-0.035)				
Intake Valve Clearance	mm (in)	0.10-0.15 (0.004-0.006)				
Exhaust Valve Clearance	mm (in)	0.20-0.24 (0.008-0.0095)				

## Tightening torque

Engine Oil Drain Bolt	24N · m (17 ft · lb, 2.4 kgf · m)
Engine Oil Filter	18N · m (13 ft · lb, 1.8 kgf · m)
Gear Oil Plug	4N · m (3 ft · lb, 0.4 kgf · m)
Propeller Nut	25N · m (18 ft · lb, 2.5 kgf · m)
Spark Plug	18N · m (13 ft · lb, 1.8 kgf · m)
PTT Manual Relief Valve	3N · m (2.2 ft · lb, 0.3 kgf · m)

ENOM00013-0

**E (EF), E (EH), E (EP)**

2

Item	Model	MFS 30D		
		E (EF)	E (EH)	E (EP)
		with basic tiller handle	with multi-function tiller handle	with RC
Overall Length	mm (in)	1113 (43.80)	1360 (53.55)	732 (28.80)
Overall Width	mm (in)	401 (15.80)	389 (15.30)	
Overall Height	mm (in)	S : 1216 (47.85) L : 1343 (52.85)		
Transom Height	mm (in)	S : 425 (16.75) L : 552 (21.75)		
Weight*1	S kg (lb)	62 (137)	64 (141)	60 (132)
	L kg (lb)	62.5 (138)	64.5 (142)	60.5 (133)
Engine Type		4 stroke		
Number of Cylinder		3		
Piston Displacement	cm <sup>3</sup> (cu.in.)	500 (30.50)		
Bore x Stroke	mm (in)	61 x 57 (2.40) x (2.25)		
Max. Output	kW (PS)	18.4 (25) 22.1 (30)		
Max. Operating Range	min <sup>-1</sup> (rpm)	25D : 5000 - 6000, 30D : 5500 - 6500		
Idle Speed	min <sup>-1</sup> (rpm)	850		
Exhaust System		Through-hub exhaust		
Lubrication System		Wet sump		
Cooling System		Water cooling		
Starting System		Electric and Recoil		
Ignition System		Flywheel Magneto CD ignition		
Alternator		12V - 17.5A		
Steering Angle	Degree	76		
Trim Position		4		
Trim Up Angle	Degree	74		
Gear Shift		Dog clutch (F-N-R)		
Gear Reduction Ratio		26 : 12 (2.17)		
Operator Sound Pressure (ICOMIA 39/94 Rev.1) dB (A)		83.2		
Hand Vibration Level (ICOMIA 38/94 Rev.1) m/s <sup>2</sup>		4	-	

Remark: Specifications are subject to change without notice.

\*1 With propeller

Tohatsu outboard is power rated in accordance with ISO8665 (propeller shaft output).

## Service data

Item		Model	MFS 30D		
			E (EF)	E (EH)	E (EP)
			with basic tiller handle	with multi-function tiller handle	with RC
Fuel	Grade	Unleaded Regular Gasoline : R+M/2: 87 or higher RON: 91 or higher			
	L (US gal)	25 (6.60)			
Engine Oil	Grade	API: SH, SJ, SL, SAE: 10W-30, 10W-40			
	mL (US/Imp.qt)	1500 (1.6/1.3) without oil filter replacement			
		1700 (1.8/1.5) with oil filter replacement			
Gear Oil	Grade	API:GL-5, SAE:80-90			
	mL (US/Imp.oz)	460 (15.6/16.2)			
PTT Fluid		ATF (Automatic Transmission Fluid) Dexron III			
Battery (minimum requirements)		64Ah/5HR (70Ah/20HR, 512CCA)			
Spark Plug		NGK DCPR6E equivalent			
Spark Plug Gap	mm (in)	0.8-0.9 (0.031-0.035)			
Intake Valve Clearance	mm (in)	0.10-0.15 (0.004-0.006)			
Exhaust Valve Clearance	mm (in)	0.20-0.24 (0.008-0.0095)			

## Tightening torque

Engine Oil Drain Bolt	24N · m (17 ft · lb, 2.4 kgf · m)
Engine Oil Filter	18N · m (13 ft · lb, 1.8 kgf · m)
Gear Oil Plug	4N · m (3 ft · lb, 0.4 kgf · m)
Propeller Nut	25N · m (18 ft · lb, 2.5 kgf · m)
Spark Plug	18N · m (13 ft · lb, 1.8 kgf · m)
PTT Manual Relief Valve	3N · m (2.2 ft · lb, 0.3 kgf · m)



# PARTS NAME

ENOM00820-0

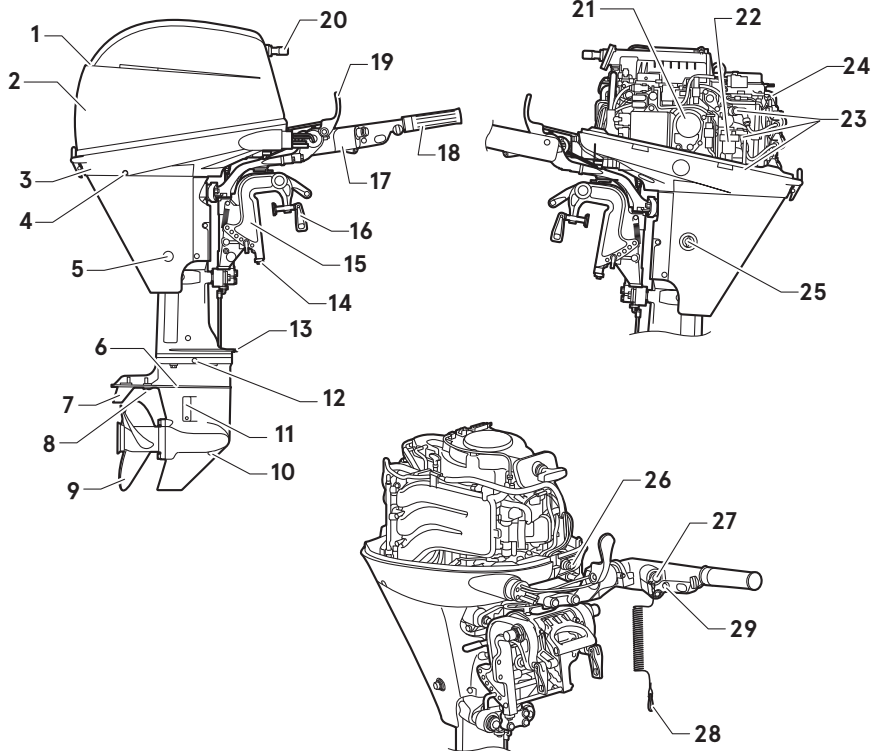
**MF**

- |                            |                          |                           |
|----------------------------|--------------------------|---------------------------|
| 1 Tilt Handle              | 13 Splash Plate          | 25 Flushing Connector Cap |
| 2 Top Cowl                 | 14 Anode                 | 26 Warning Lamp           |
| 3 Bottom Cowl              | 15 Clamp Bracket         | 27 Stop Switch            |
| 4 Cooling Water Check Port | 16 Clamp Screw           | 28 Stop Switch Lanyard    |
| 5 Oil Drain Plug           | 17 Basic Tiller Handle   | 29 Push Switch            |
| 6 Anti-ventilation Plate   | 18 Throttle Grip         |                           |
| 7 Trim Tab                 | 19 Shift Lever           |                           |
| 8 Sub-water Inlet          | 20 Recoil Starter Handle |                           |
| 9 Propeller                | 21 Oil Filter            |                           |
| 10 Oil Plug (Lower)        | 22 Fuel Filter           |                           |
| 11 Cooling Water Inlet     | 23 Spark Plug            |                           |
| 12 Oil Plug (Upper)        | 24 Oil Filler Cap        |                           |

ENOF02503-0

ENOM00020-0

**E (with basic tiller handle)**

3

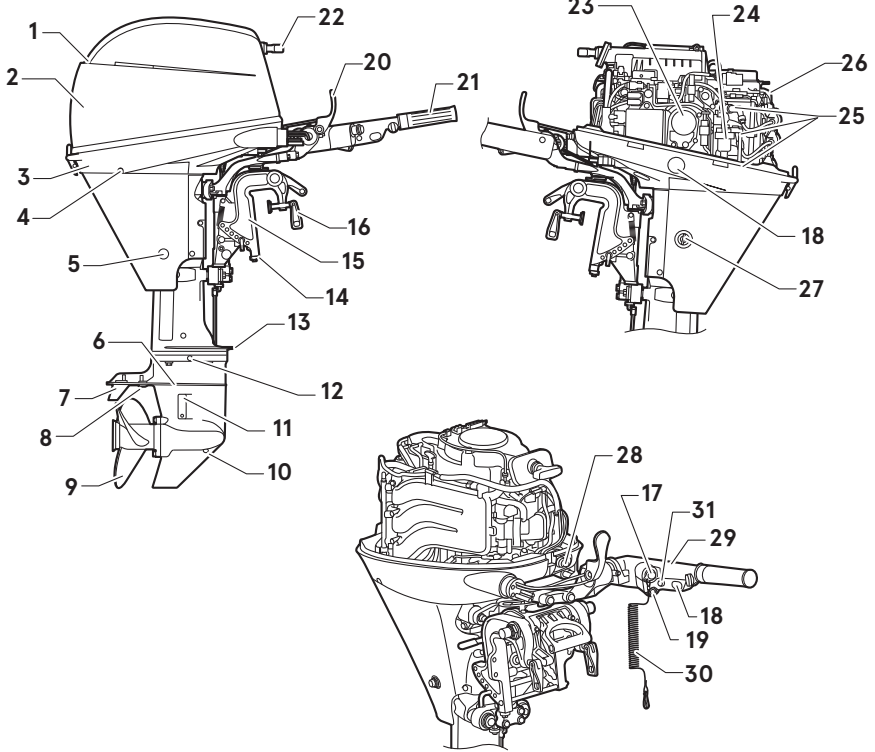

ENOF02504-0

- |                            |                          |                           |
|----------------------------|--------------------------|---------------------------|
| 1 Tilt Handle              | 13 Splash Plate          | 25 Spark Plug             |
| 2 Top Cowl                 | 14 Anode                 | 26 Oil Filler Cap         |
| 3 Bottom Cowl              | 15 Clamp Bracket         | 27 Flushing Connector Cap |
| 4 Cooling Water Check Port | 16 Clamp Screw           | 28 Warning Lamp           |
| 5 Oil Drain Plug           | 17 Stop Switch           | 29 Basic Tiller handle    |
| 6 Anti-ventilation Plate   | 18 PT Switch *1          | 30 Stop Switch Lanyard    |
| 7 Trim Tab                 | 19 Start Switch          | 31 Push Switch            |
| 8 Sub-water Inlet          | 20 Shift Lever           | *1: Power tilt type only  |
| 9 Propeller                | 21 Throttle Grip         |                           |
| 10 Oil Plug (Lower)        | 22 Recoil Starter Handle |                           |
| 11 Cooling Water Inlet     | 23 Oil Filter            |                           |
| 12 Oil Plug (Upper)        | 24 Fuel Filter           |                           |

ENOM00020-0

## ET (with multi-function tiller handle)

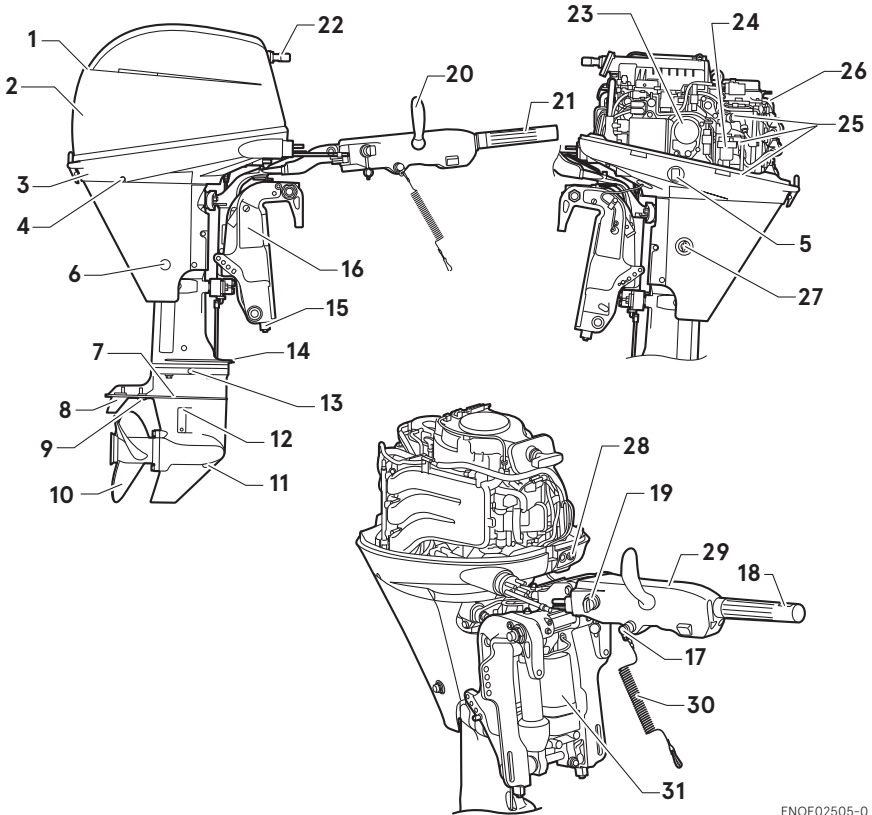

- |                            |                          |                                      |
|----------------------------|--------------------------|--------------------------------------|
| 1 Tilt Handle              | 13 Oil Plug (Upper)      | 25 Spark Plug                        |
| 2 Top Cowl                 | 14 Splash Plate          | 26 Oil Filler Cap                    |
| 3 Bottom Cowl              | 15 Anode                 | 27 Flushing Connector Cap            |
| 4 Cooling Water Check Port | 16 Clamp Bracket         | 28 Warning Lamp                      |
| 5 PT Switch                | 17 Stop Switch           | 29 Multi-function Tiller handle *1   |
| 6 Oil Drain Plug           | 18 PT Switch             | 30 Stop Switch Lanyard               |
| 7 Anti-ventilation Plate   | 19 Main Switch           | 31 Power Tilt                        |
| 8 Trim Tab                 | 20 Shift Lever           | *1: Multi-function tiller model only |
| 9 Sub-water Inlet          | 21 Throttle Grip         |                                      |
| 10 Propeller               | 22 Recoil Starter Handle |                                      |
| 11 Oil Plug (Lower)        | 23 Oil Filter            |                                      |
| 12 Cooling Water Inlet     | 24 Fuel Filter           |                                      |

ENOF02505-0

ENOM00822-0

## Remote control box & Fuel tank

3

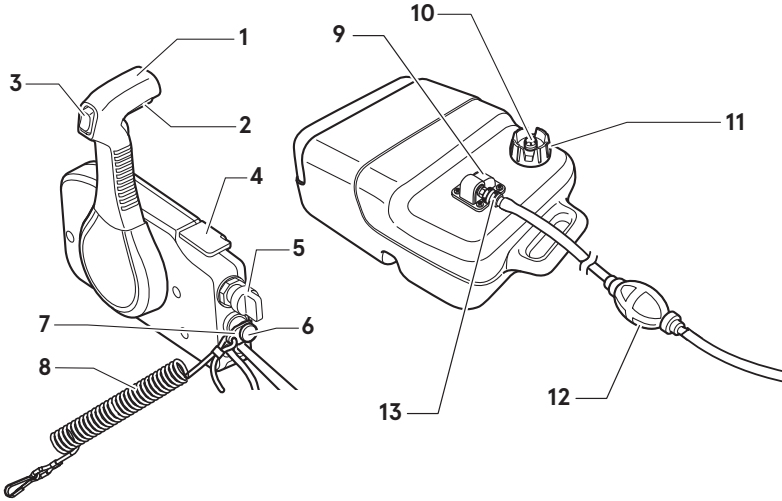

- |   |                     |    |                                 |
|---|---------------------|----|---------------------------------|
| 1 | Control Lever       | 9  | Fuel Gauge                      |
| 2 | Neutral lock arm    | 10 | Air Vent Screw                  |
| 3 | PT switch           | 11 | Fuel Tank Cap                   |
| 4 | Free throttle lever | 12 | Primer Bulb                     |
| 5 | Main switch         | 13 | Fuel Connector (Fuel tank side) |
| 6 | Stop switch         |    |                                 |
| 7 | Stop switch lock    |    |                                 |
| 8 | Stop switch lanyard |    |                                 |

ENOF02539-0

# LABEL LOCATIONS

ENOM00019-A

## Warning label locations

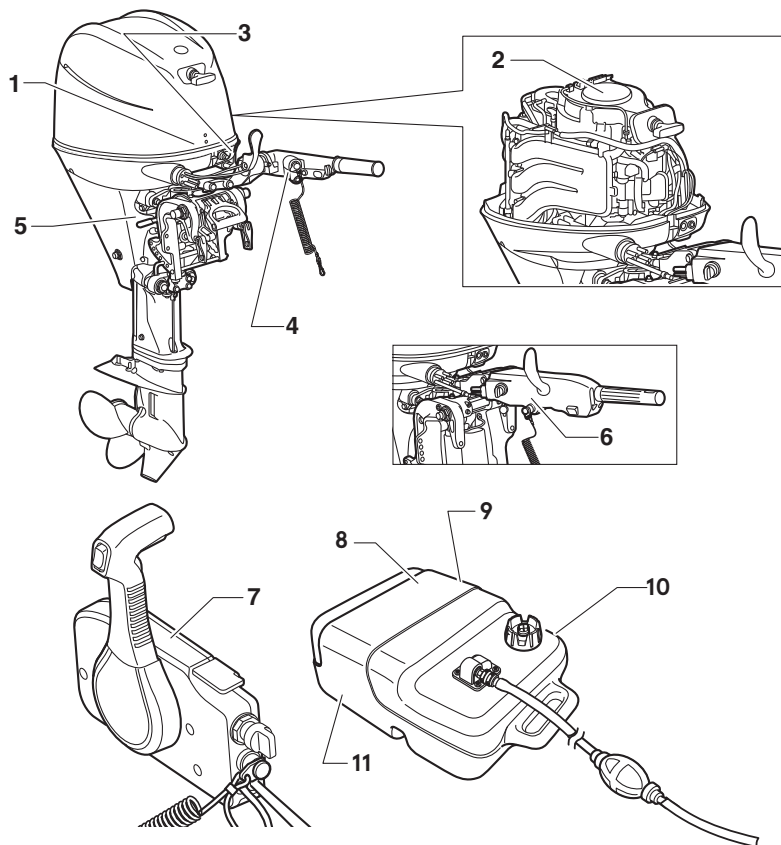

4

ENOF02506-0

1. Read owner's manual.



ENOF00120-0

- 2-1. Warning regarding starting the engine (See page 39).

**2-2. HOT SURFACE**

Can cause burns.

Do not touch when operating or immediately after the engine has stopped.

**2-3. HAZARD CAUSED BY ROTATING PARTS**

Rotating parts can cause severe injury.

Keep hands, feet, hair, and clothing away from all rotating parts to prevent injury.

**2-4. ELECTRICAL SHOCK HAZARD**

High voltage can cause severe electrical shock.

Do not touch electrical components such as ignition coil or spark plug cord when starting or while the engine is in operation.

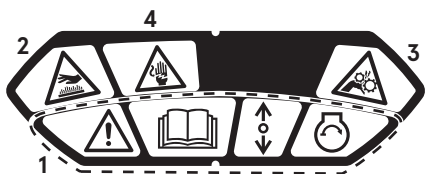

3PA-72181-1

3. Warning lamp (See page 35).



ENOF00130-0

4. Engine stop switch (See page 42, 50 and 52)



ENOF00131-B

5. When laying down the outboard motor, be sure this decal is facing up.



3H6-67572-1

**For multi-function tiller handle model**

6. Warning regarding stop switch (See page 42 and 44)



3GF-72200-1

**For RC model**

7. Warning regarding stop switch lanyard.



ENOF00008-1

8. Warning regarding gasoline.

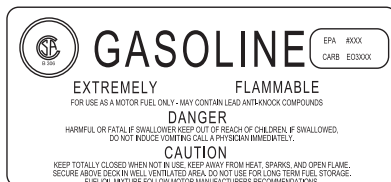

ENOF00005-E

9. Warning regarding gasoline (See page 30).



ENOF00005-L

10. Warning regarding gasoline (See page 30).



ENOF00005-M

11. Warning regarding gasoline (See page 30).

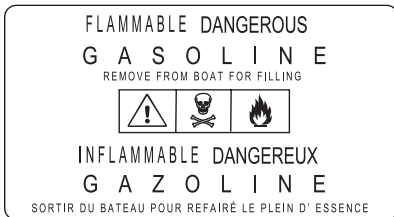

ENOF00005-F

ENOM00019-B

## CE label locations

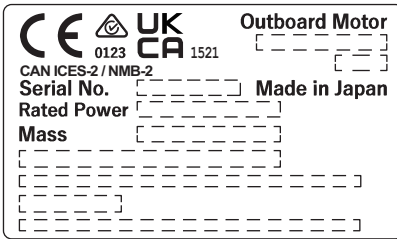

- 1)
- 2)
- 3)
- 4)
- 5)
- 6)
- 7)
- 8)

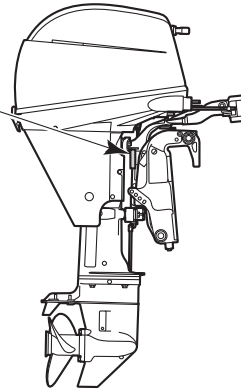

4

ENOF02558-0

1. Model code (Model name)
2. Serial No.
3. Rated power
4. Dry mass weight (Without propeller, with battery cable)
5. Manufacturer name
6. Manufacturer address
7. Authorised representative
8. Authorised representative address

Description of serial number year code  
 Last two digits of alphabet represent production year as below.

Year Code	BB	BC	BD	BE	BF
Year of manufacture	2022	2023	2024	2025	2026



# INSTALLATION

ENOM00024-A

## 1. Mounting the outboard motor on boat

ENOW00006-1B

### ! WARNING

To avoid personal injury or damage of equipment, make sure the allowable lifting capacity of the hoist is at least twice the weight of the outboard motor.

Do not allow the lift hook or chain from the hoist to come in contact with any part of the outboard motor during lifting.

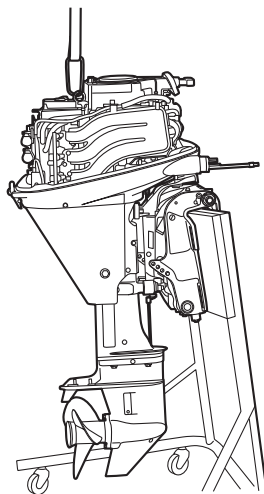

ENOF02508-0

ENOW00006-1

### ! WARNING

Most boats are rated and certified for their maximum allowable horsepower, as shown on the boat's certification plate. Do not equip your boat with an outboard motor that exceeds this limit. If in doubt, contact your dealer.

Do not operate the outboard motor until it has been securely mounted on the boat in accordance with the instructions below.

ENOW00009-2A

### ! WARNING

- Mounting the outboard motor without following this manual can lead to unsafe conditions such as poor maneuverability, lack of control or fire.
- Loose clamp screws and/or mounting hardware can lead to the release or displacement of the outboard motor, possibly resulting in loss of control and/or serious personal injury. Be sure that fasteners are tightened to the specified torque. Check the fasteners for tightness before operating your outboard.
- Be sure to use outboard mounting hardware included in the outboard motor package or their equivalents in terms of size, material, quality and strength.

5

Mounting outboard motor must be performed by trained service person(s) in well-equipped place where lift or hoist can be used.

ENOM00025-0

### Position ... Above keel line

Place the outboard motor in the center of the boat's transom.

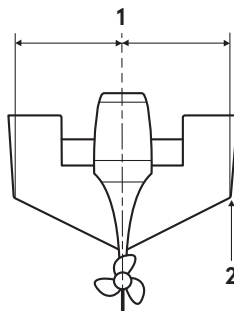

ENOF02406-0

1. Center of boat
2. Chine

ENOM00026-A

## Transom matching

Be sure that the anti ventilation plate of the outboard motor is 0–25 mm (0–1 in) below the bottom of hull.

If the above condition cannot be met due to the shape of the bottom of your boat, please consult your authorized dealer.

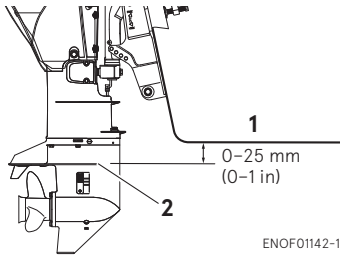

1. Bottom of hull
2. Anti ventilation plate

ENOW00007-1

### CAUTION

- Before running test, check the boat with maximum loading capacity. Overloading or incorrect weight distribution of the weight may result in boat to lose control, even swamping or capsizing. Make sure that there is enough distance between bottom cowl and water surface to prevent water from entering the engine.
- Make sure to mount the engine in correct position. If outboard motor is mounted incorrectly, water may intrude the engine from openings of the bottom cowl while cruising. Exposing the engine to such condition may result in severe damage to the engine.

ENOM00832-A

## Mounting the outboard motor

### Manual tilt type

1. Set the outboard motor to appropriate position.
2. Tighten the clamp screws by turning their handles.
3. Secure the clamp brackets to the transom board using bolts, flat washers and nylon locking nuts.
4. Secure the outboard motor to the boat with a rope to prevent accidental loss of the outboard motor overboard.

ENON00930-1

### Note

- Do not use tools to tighten clamp screws. Over tightening could result in damage to the clamp screws and clamp brackets.
- Do not reuse nylon locking nut.

ENON00002-0

### Note

A rope is not included in the standard accessories.

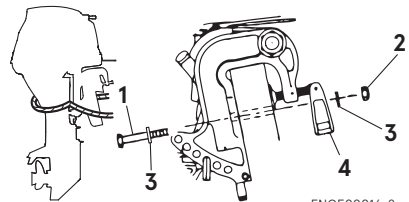

1. Bolt (8 × 85)
2. Nylon locking nut
3. Washer
4. Clamp screw

ENOW00945-0

**⚠ CAUTION**

- Please inspect whether there is a loosening of the clamp screw or mounting bolts before departure.
- Loosening may cause a dangerous situation, such as loss of control.

**PT type**

1. Set the outboard motor to appropriate position.
2. Secure the clamp brackets to the transom board using bolts, flat washers and nylon locking nuts.

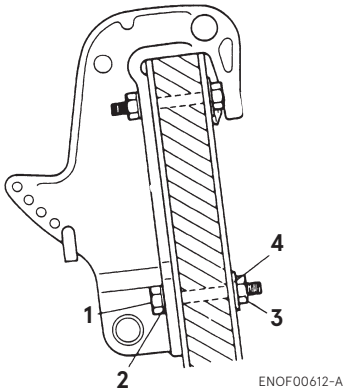

1. Bolt (12 × 105)
2. Washer (small diameter)
3. Nylon locking nut
4. Washer (large diameter)

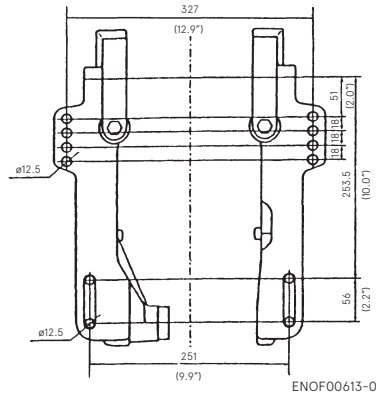

ENOW00008-2

**⚠ CAUTION**

- Install upper mounting bolts from the boat side. Exposing threaded side of bolts on the boat side can cause personal injury.
- Tighten the bolts securely, otherwise the outboard motor could fall down.

ENON00948-0

**Note**

- Apply sealing agent, such as silicone sealant between the bolts and the transom board holes before tightening the bolts.
- Do not reuse nylon locking nut.

ENOM00029-A

## 2. Battery installation

ENOW00012-1

### WARNING

Battery electrolyte contains sulfuric acid and is hazardous, causes a burn if come in contact with your skin, and poisonous if swallowed.

Keep battery and electrolyte away from reach of children.

When handling the battery, be sure to:

- Read all warnings shown on the battery case.
- Prevent electrolyte from coming in contact with any part of your body. Contact can cause serious burn or, if come in contact with your eye, loss of sight. Use safety glasses and rubber gloves.

In case you came in contact with battery electrolyte:

- For skin, flush thoroughly with water.
- For eye, flush thoroughly with water, and then seek immediate medical treatment.

In case battery electrolyte is swallowed:

- Seek immediate medical treatment.

ENOW00013-A

### WARNING

Battery generates explosive hydrogen gas. Be sure to:

- Charge the battery in a well-ventilated place.
- Place the battery away from any source of fire, sparks and open flames such as burners or welding equipment.
- Do not smoke near the battery when the battery is charging.
- Do not charge the battery when the electrolyte level is low. Otherwise, the battery will be damaged and may cause malfunction.

ENOW00014-0

### CAUTION

- Make sure that the battery leads do not get stuck between the outboard motor and boat when turning, etc.
- The starter motor may fail to operate if the leads are incorrectly connected.
- Be sure to correctly connect the (+) and (-) leads. If not, the charging system will be damaged.
- Do not disconnect the battery leads from battery while the engine is operating, the electrical parts could be damaged.
- Always use a fully charged battery.

ENOW00015-1

### CAUTION

Do not use a battery that is not recommended. Use of a battery not recommended can lead to poor performance of, and/or damage to the electrical system.

ENON00006-1E

#### Note

**Minimum battery requirements: 12v 70Ah/20HR, 512 Cold Cranking Amps (CCA).**

Larger capacity battery is required when it is used under a freezing condition.

Recommend connecting only the engine battery cables to the starting battery.

Specifications and features of battery vary by manufacturers.

Consult the manufacturer for details.

\* The battery should be purchased separately and is not supplied with the outboard motor.

1. Place the battery box in a convenient position and away from possible water spray. Securely fasten both the box and the battery so they do not shake loose.
2. Connect the positive lead (+) to the positive terminal (+) of the battery, and then connect the negative lead (-). When disconnecting the battery, always remove the negative lead (-) first. After connecting the positive terminal (+), securely place a cap on it to prevent short circuits.

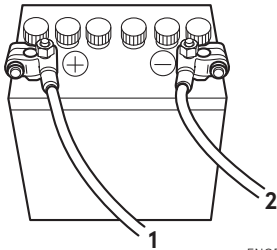

ENOF00022-1

1. Battery cord (red)
2. Battery cord (black)

ENOM00971-0

### 3. TOCS (Tohatsu Onboard Communication System) installation\*

TOCS (Tohatsu Onboard Communication System) interface coupler can provide information regarding engine speed, fuel consumption, and various malfunction via an optional interface cable. Contact authorized Tohatsu dealer for more details.

\* Electric start model only

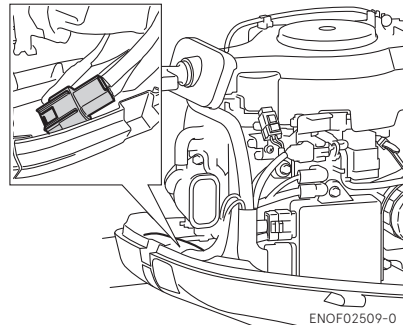

ENOF02509-0

# PRE-OPERATING PREPARATIONS

ENOM00030-A

## 1. Fuel handling

ENOW000017-0

### CAUTION

**Use of improper gasoline can damage your engine. Engine damage resulting from the use of improper gasoline is considered misuse of the engine, and damage caused thereby will not be covered under the limited warranty.**

ENOM00031-1

## FUEL RATING

Use only major brand unleaded fuel meeting the following specifications:

**USA and Canada** – having a posted pump Octane Rating of 87 (R+M)/2 minimum. Premium gasoline (92 [R+M]/2 Octane) is also acceptable. Do not use leaded gasoline.

**Outside USA and Canada** – Use unleaded gasoline with declared octane rating of 91 RON or over. Use of premium gasoline of 98 RON is also allowed.

ENOM00032-1

## GASOLINES CONTAINING ETHANOL

The fuel system components on your TOHATSU outboard motor will withstand up to 10% ethyl alcohol (hereinafter referred to as the "ethanol") content in the gasoline. If the gasoline in your area contains ethanol, be aware of certain adverse effects that can occur. Increasing the percentage of ethanol in the fuel can also worsen these adverse effects. Some of these adverse effects are caused by ethanol absorbing moisture in

the air, which leads to separation of the water/ethanol from the gasoline in the fuel tank.

Use of gasoline containing ethanol may accelerate:

- Corrosion of metal parts
- Deterioration of rubber or plastic parts
- Fuel permeation through rubber fuel lines
- Starting and operating difficulties

If the use of gasoline containing ethanol cannot be avoided or presence of ethanol is suspected in the gasoline, it is recommended to use a filter to separate water, and frequently check the fuel system for leaks, mechanical parts for corrosion and abnormal wear.

In case any of such abnormality is found, discontinue the use of such gasoline and contact our dealer immediately.

If the outboard motor will only be used infrequently, please see the remarks on fuel deterioration in the STORAGE chapter (P 86) for additional information.

ENOW00975-0

### CAUTION

**When operating an outboard motor with gasoline containing ethanol, storing gasoline in the fuel tank for long periods should be avoided. Storing gasoline for long periods creates unique problems. In cars, ethanol blended fuels are normally consumed before they can absorb enough moisture to cause problems, but boats often sit idle long enough for separation phase to take place. In addition, internal corrosion may take place during storage if ethanol washes away the oil films protecting internal components.**

ENOW00018-1

 **WARNING**

Fuel leakage can cause fire or explosion, potentially leading to severe injury or loss of life. Every part of fuel system should be inspected periodically. Inspect for fuel leak, hardness or any alteration of rubber, expansion and/or corrosion of metals especially after long term storage. In case any indication of fuel leakage or degradation in fuel system is found, replace the part immediately before using the outboard motor.

ENOM00043-B

**2. Fuel filling**

ENOW00976-0

 **WARNING**

Do not fill the fuel tank over capacity. Under high temperature conditions, excessive gasoline may evaporate/leak through air vent screw when it is loose or open. Leaking of gasoline is a may lead to a dangerous fire hazard.

ENOW00028-1

 **WARNING**

Consult an authorized dealer for details on handling gasoline, if necessary.

Gasoline and its vapor are very flammable and can be explosive.

When carrying a fuel tank containing gasoline:

- Close the fuel tank cap and air vent screw of fuel tank cap, or gasoline may evaporate through the air vent screw and may lead to a fire hazard.
- Do not smoke.

When or before refueling:

- Be sure to remove the static electricity charged in your body before refueling.

- The static electricity may ignite the gasoline vapor during refueling.
- Stop the engine, and do not start the engine during refueling.
- Do not smoke.
- Be careful not to overfill fuel tank. Wipe up any spilled gasoline immediately.

When or before cleaning the gasoline tank:

- Dismount fuel tank from the boat.
- Place the fuel tank away from every source of ignition, such as sparks or open flames.
- Do the work outdoors or in a well ventilated area.
- Wipe up gasoline well immediately if spilled.

After cleaning gasoline tank:

- Wipe up gasoline well immediately if spilled.
- If the fuel tank is disassembled for cleaning, reassemble carefully. Incorrect assembly may cause a fuel leak, possibly leading to fire or explosion.
- Dispose aged or contaminated gasoline in accordance with local regulations.

ENOW00029-1

 **WARNING**

When opening fuel tank cap, be sure to follow the procedure described below. Fuel could blast out if the fuel tank cap is opened by using another procedure when internal pressure of fuel tank is raised by heat from sources such as sun light.

ENOW00946-0

 **CAUTION**

Separate tank must be fixed at appropriate position so that well ventilated and tank does not move or fall down while operating.

1. Fully open the air vent screw on the fuel tank cap and release internal pressure.

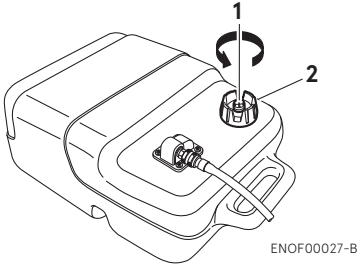

1. Air vent screw
2. Fuel tank cap

- 6**
2. Open the fuel tank cap slowly.
  3. Fill the fuel carefully not to over flow.

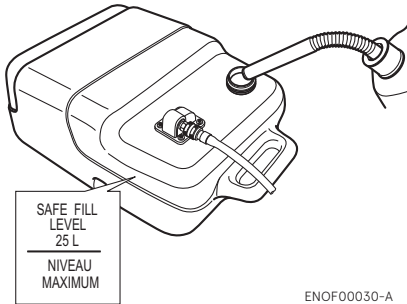

4. After filling the tank, close the fuel tank cap.

ENOM00037-D

### 3. Engine oil filling

ENOW00022-2

#### **⚠ CAUTION**

The engine oil is drained for shipping at the factory. Be sure to fill the engine oil to the proper level before starting the engine.

ENOW00092-1

#### **⚠ CAUTION**

- Do not overfill engine oil, or engine oil could leak and/or engine could be damaged. If engine oil level is over upper limit marks of dip stick, drain oil to level lower than upper limit.
- Be sure that outboard motor is upright when checking or changing oil.
- Stop the engine immediately if low oil pressure warning lamp or oil leak is found, or engine could be severely damaged. Consult your dealer.
- Wipe off engine oil well immediately if spilled and dispose of it in accordance with local fire prevention and environment protection regulations.

1. Place the engine in a vertical position.
2. Remove the top cowl and the oil filler cap.
3. Fill the engine through filler port with recommended oil to between upper limit and lower limit shown on the dipstick.
4. Tighten the oil filler cap.



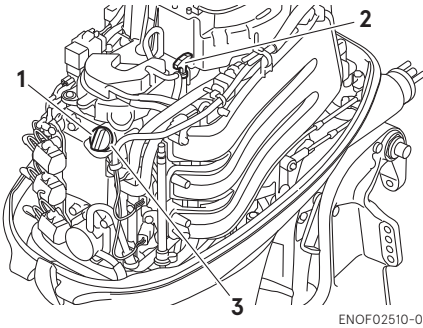

- 1. Filler cap
- 2. Dipstick
- 3. Filler port

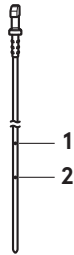

- 1. Upper limit
- 2. Lower limit

**Engine oil recommendation**

Use only high quality 4-stroke outboard motor oil to insure performance and prolonged engine life.

SAE: 10W-30 or 10W-40

API: SH, SJ or SL

Engine oil viscosity must be selected from the following chart according to the average temperatures in your area.

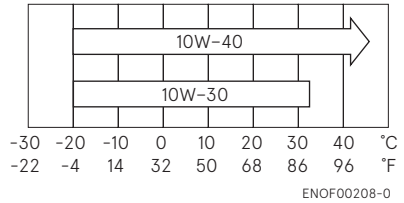

**Engine oil volume (with out oil filter replacement)**  
 Approximately 1500 mL (1.6/1.3 US/Imp. qt.)

ENOW0002A-A

**CAUTION**

Use of engine oils that do not meet these requirements will result in reduced engine life, and other engine problems.

ENOM00033-A

## 4. Break-In

Your new outboard motor and lower unit require break-in for the moving components according to the conditions described in the following time table.

Please refer to ENGINE OPERATION section (See page 38) to learn how to correctly start and operate the outboard motor.

ENOW00024-1

### DANGER

**Do not operate the outboard motor in closed area or area with not enough ventilation.**

**Exhaust gas emitted by the outboard motor contains carbon monoxide that may cause dizziness, nausea, other health problem or even death if inhaled continuously.**

**During operation of the outboard motor:**

- **Keep peripheral area well ventilated.**
- **Always stay on the windward side of emission.**

ENOW00023-1

### CAUTION

**Operating the outboard motor without break-in can shorten life.**

**If any abnormality is experienced during the break-in:**

- **Discontinue the operation immediately.**
- **Have the dealer check the product and take proper action(s) if necessary.**

ENON00008-2

### Note

- During Break-in, run the outboard motor at varied RPM less than specified engine speed. Not following the procedure may result in problems and may shorten the product life.
- Break-in must be conducted under load in the water in-gear with propeller installed.

	1-10 min	10 min – 2 hrs	2-3 hrs	3-10 hrs	After 10 hrs
Throttle Position	Idle	Less than 1/2 throttle	Less than 3/4 throttle	3/4 throttle	Full throttle available
Speed		Approx. 3000 min <sup>-1</sup> (rpm) max	Full throttle run allowed for 1 min every 10 min	Approx. 4000 min <sup>-1</sup> (rpm). Full throttle run allowed for 2 min every 10 min	

ENOM00039-1

## 5. Warning system

If outboard motor encounters an abnormal condition of fault, the warning buzzer will emit a continuous beep or intermittent short beeps. The warning lamp (LED) will synchronize with the buzzer and engine speed will be limited (engine will not stop).

See next page for conditions which will lead to an abnormal condition or fault.

ENOM00040-A

### Location of warning buzzer and lamp

#### ■ Warning buzzer

RC model: Located inside the remote control.

Multi-Function tiller handle model: Located in the tiller handle.

Tiller handle model: Located in the engine cover.

#### ■ Warning lamp (LED)

RC model: Located in the tachometer & bottom cowl.

Multi-Function tiller handle & Tiller handle models: Located on the bottom cowl.

ENON00009-A

### Note

Warning lamp for optional tachometer will synchronize with the warning lamp on engine side

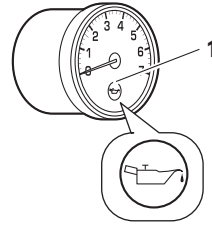

ENOF00851-A

1. Warning lamp

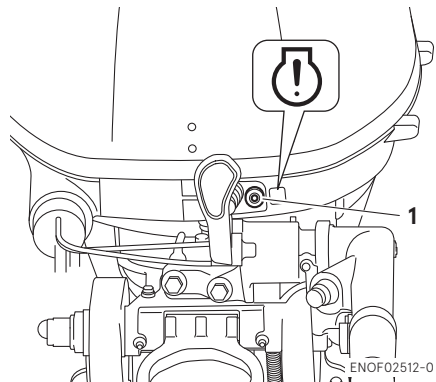

ENOF02512-0

1. Warning lamp

ENOM00041-B

**Warning indicators, faults and remedy**

Warning indicators				Description of faults	Remedy
Sound	Lamp (LED)	Low speed ESG	High speed ESG		
1 sec.	1 sec.			Normal system test when start up. <sup>*1</sup>	
Continuous	ON		ON	Engine speed exceeds maximum allowable RPM	<b>1</b>
Continuous <sup>*2</sup>	ON <sup>*2</sup>	ON <sup>*2</sup>		Low oil pressure	<b>2</b>
Continuous <sup>*2</sup>	ON <sup>*2</sup>	ON <sup>*2</sup>		Cooling water Temperature is high.	<b>3</b>
Intermittent short beep <sup>*2</sup>	Blinking <sup>*2</sup>	ON <sup>*2</sup>		Water temp or MAP sensor out of range	<b>4</b>

## Remarks

\*1: Remote control model and multi-tiller handle model: The buzzer and lamp (LED) are activated when the key is turned on.

Basic tiller handle model: The buzzer and lamp (LED) are activated when pulling the recoil starter or running the starter motor.

\*2: It is necessary to stop the engine, if you want to reset the warning system.

**High speed ESG (Electronic Safety Governor)**

High speed ESG is a device to prevent over revolution of the engine. If the load to the engine becomes light for some reason, it runs at a higher speed than the usual. In such the case, the buzzer sounds and the ESG is activated not to ignite the spark plug. Therefore, the engine speed varies and is controlled following specified engine speed.

**MFS 30D: 6700 min<sup>-1</sup> (rpm)**

**MFS 25D: 6200 min<sup>-1</sup> (rpm)**

**Low speed ESG**

Low speed ESG is a device to prevent the engine from getting damage. If the engine has problems regarding cooling water, oil pressure, and sensors, the low speed ESG is activated not to ignite the spark plug, and disable fueling. Therefore, the engine speed varies and is controlled under 2800min<sup>-1</sup> (rpm).

ENOM00126-0

**Remedy**

1. Reduce the speed to less than half open throttle, and move to safe place quickly, and stop the engine.  
Check the propeller for bent or damage on blades.  
Consult an authorized dealer if engine shows the same result even after replacing propeller with a new one.
2. Move to safe place quickly, and stop the engine until it cools down.  
Check the engine oil level, and add engine oil if necessary.  
Consult your dealer if the engine oil level is too low or too high.
3. Move to safe place quickly, and check if cooling water is discharged from the water check port at idle speed and stop the engine.  
Remove any foreign matter on the gear case and propeller if necessary.  
Consult an authorized dealer if no discharge of cooling water.
4. Consult an authorized dealer.

ENOW00985-0

**CAUTION**

- **Low speed ESG ON: Engine speed will be limited to 2800 min<sup>-1</sup> (rpm), however you should not continue to run engine.**
- **High speed ESG ON: Engine speed will be limited to specified engine speed and engine will run rough until throttle is reduced.**  
MFS 30D: 6700 min<sup>-1</sup> (rpm)  
MFS 25D: 6200 min<sup>-1</sup> (rpm)

# ENGINE OPERATION

ENOM00042-0

## Before starting

ENOM00246-0

### Oil Level checking

Check the engine oil level before each use. If the oil level is low or too high, the life of the engine will be shortened significantly. (To properly check the engine oil level, follow the instructions, see page 68)

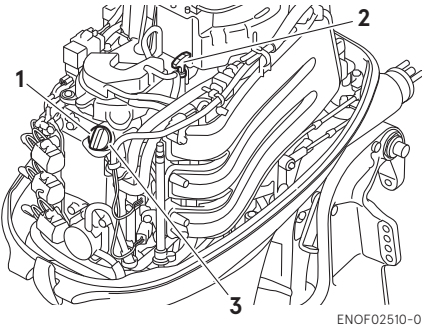

1. Filler cap
2. Dipstick
3. Filler port



1. Upper limit
2. Lower limit

ENOW00027-B

## ⚠ CAUTION

Before starting engine for the first time after reassembling engine or off-season storage, disconnect stop switch lock and crank approximately 10 times in order to prime the oil pump.

ENOM01900-0

## 1. Fuel feeding

ENOW00029-1

## ⚠ WARNING

When opening fuel tank cap, be sure to follow the procedure described below. Fuel could blast out if the fuel tank cap is opened by using another procedure when internal pressure of fuel tank is raised by heat from sources such as sun light.

ENOW00947-0

## ⚠ CAUTION

When using a separate tank, be sure that the fuel line is not kinked and is connected securely.

1. Fully open the air vent screw on the fuel tank cap.

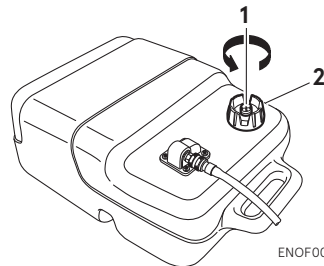

1. Air vent screw
2. Fuel tank cap

- Open the fuel tank cap slowly and release internal pressure completely. After that, close the fuel tank cap.

### Connector type

3-1. Connect the fuel connector to the engine and fuel tank.

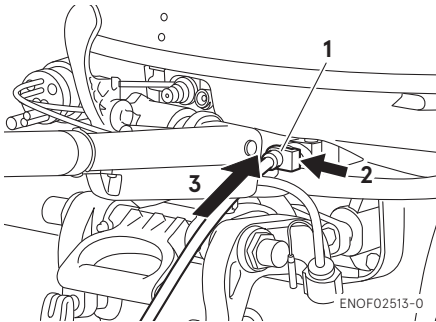

- Fuel connector
- Push
- Insert

ENOF02513-0

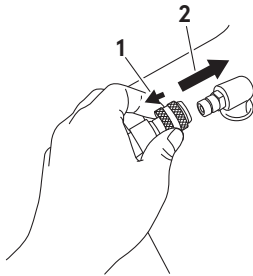

- Pull
- Insert

ENOF00861-A

### Hose joint type

- Remove the cap from the fuel joint. Connect the fuel hose of the primer bulb and secure with a hose band.
- Connect the primer bulb to the fuel tank.

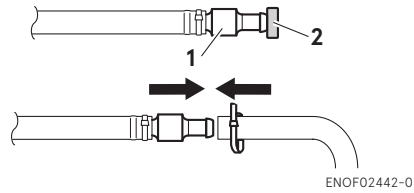

ENOF02442-0

- Joint
- Cap
- Squeeze primer bulb until it becomes stiff to feed fuel to vapor separator. Point the arrow mark upward when priming.



ENOF00862-0

- Engine side
- Fuel tank side

Do not squeeze primer bulb with engine running or when the outboard motor is tilted up to avoid fuel from overflowing.

ENOM00045-A

## 2. Starting the engine

ENOW00958-1



- Do not remove or install the top cowl after the engine has started.
- The exposed rotating engine parts cause serious injury.

ENOW00959-0

**⚠ CAUTION**

The top cowl must be installed while the engine running except in an emergency. If the top cowl is not installed correctly, water splash can damage the engine.

ENOW00036-1A

**⚠ CAUTION**

When starting the outboard motor in the test tank, make sure that:

1. Water level is at least 10 cm (4 in.) above the anti-ventilation plate to avoid overheating of the engine.
2. Run at idling only
3. Remove the propeller (See page 81)

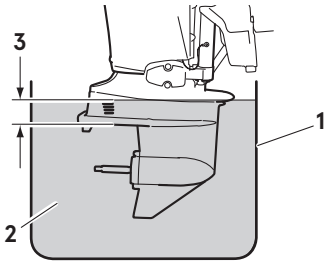

ENOF00863-0

1. Test tank
2. Water
3. Over 10 cm (4 in.)

ENOW00036-1

**⚠ CAUTION**

Operating outboard motor without cooling water will lead to overheating and damage on the outboard motor severely. In case the cooling water check port is not discharging water, stop the outboard motor immediately, check for any object, debris which may be blocking the cooling water check port. If you are unable to locate the cause, consult an authorized dealer immediately.

ENOW00032-A

**⚠ CAUTION**

Do not hold turning starter motor more than 5 seconds, or the battery may be consumed, potentially making the engine starting impossible and/or damaging the starter.

If cranking over 5 seconds fails to start engine, return main switch to "ON", and crank engine again after 10 seconds or more. Do not try to crank after engine has started.

This model is provided with start in gear protection.

ENON00010-1

**Note**

Start-in-gear protection prevents the engine from starting at other than neutral shift. In-gear starting of engine will move the boat immediately, potentially leading to fall down or causing passenger(s) to be thrown overboard.

**Basic tiller handle type**

1. Be sure to install the stop switch lock to the stop switch, and attach the stop switch lanyard securely to the operator or to the operator's PFD (Personal Flotation Device.)

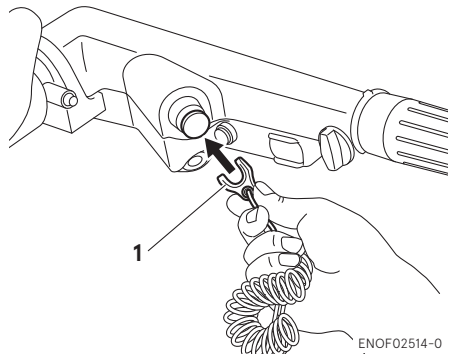

ENOF02514-0

1. Stop switch lock



2. Set the shift lever in the Neutral position.

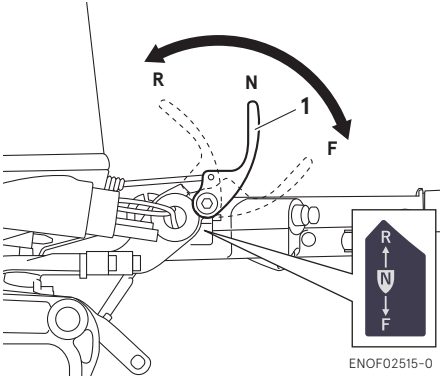

1. Shift lever

3. Set the throttle grip to START position.

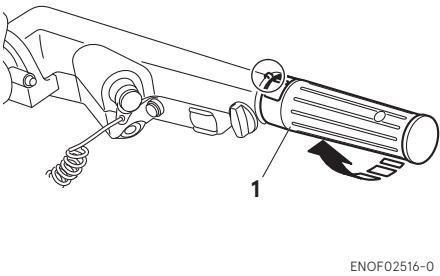

1. Throttle grip

**(For manual starter type)**

This engine is equipped with a compression release mechanism.

4. Pull the starter handle slowly until you feel engagement, keep pulling till you feel less resistance. Then pull it quickly. Repeat the procedure until the outboard motor is started.

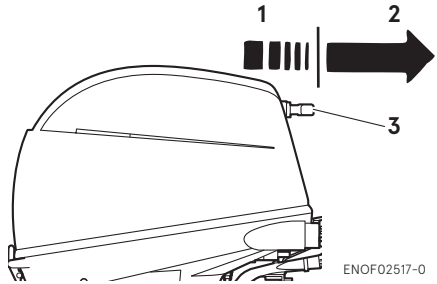

1. Slowly
2. Quickly
3. Starter handle

**(For electrical starter type)**

4. Push the starter switch button and release the button when the engine has started.

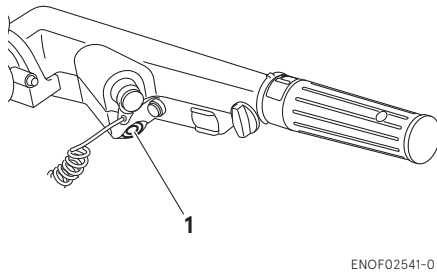

1. Starter Button

**Multi-function tiller handle type**

1. Be sure to install the stop switch lock to the stop switch, and attach the stop switch lanyard securely to the operator or to the operator's PFD (Personal Flotation Device.)

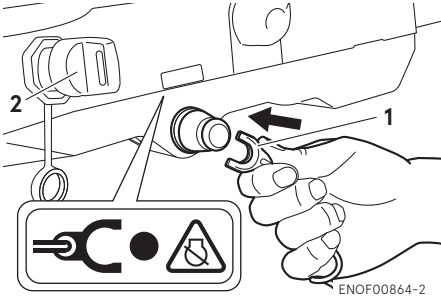

1. Stop switch lock
2. Main switch key

7

2. Insert the main switch key.
3. Set the shift lever in the Neutral position.

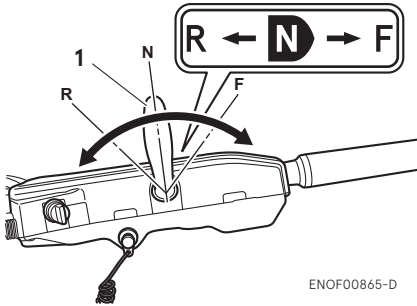

1. Shift lever
- ENOW00031-0

**⚠ CAUTION**

**If the engine starts in gear, do not use it. Contact an authorized dealer.**

4. Set the throttle grip to START position.

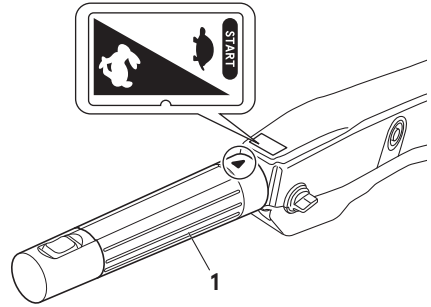

ENOF00866-2

1. Throttle grip
5. Turn the main switch key to ON position.

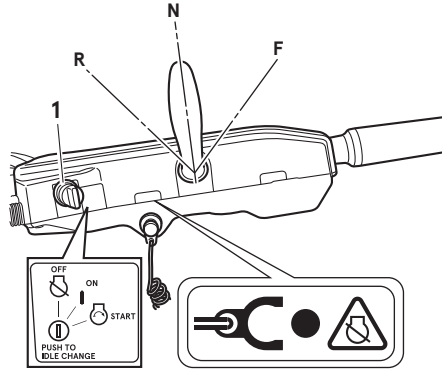

ENOF00867-3

1. Main switch key
6. Turn the main switch key to START position and release the key when engine has started. Also, confirm warning lamp light up with beep sound and then lights out. The key returns to the original position automatically.

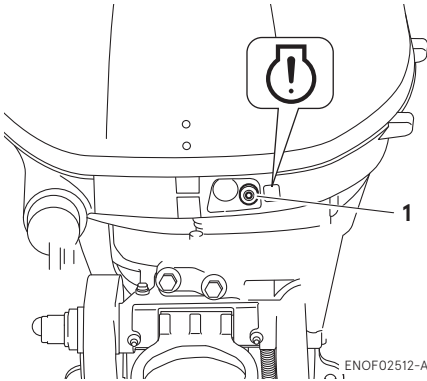

1. Warning lamp

ENOW00032-1

**CAUTION**

**Do not hold turning starter motor more than 5 seconds, or the battery may be consumed, potentially making the engine starting impossible and/or damaging the starter. If cranking over 5 seconds fails to start engine, return main switch to "ON", and crank engine again after 10 seconds or more.**

7. Make sure that water is being discharged from the cooling water check port.

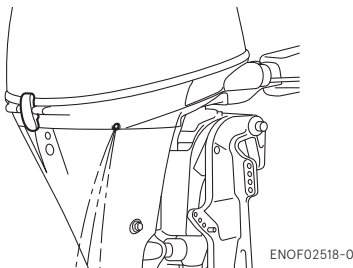

ENOF02518-0

**Side mount RC type**

1. Be sure to install the stop switch lock to the stop switch, and attach the stop switch lanyard securely to the operator or to the operator's PFD (Personal Flotation Device.)

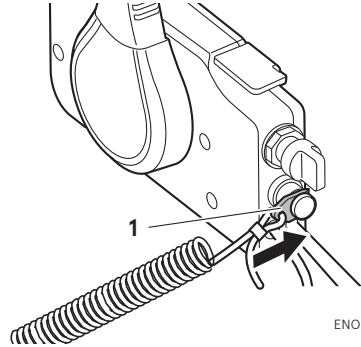

ENOF00869-1

1. Stop switch lock
2. Insert the main switch key.
3. Set the control lever in the Neutral position. Do not raise the free throttle lever when starting the engine.

7

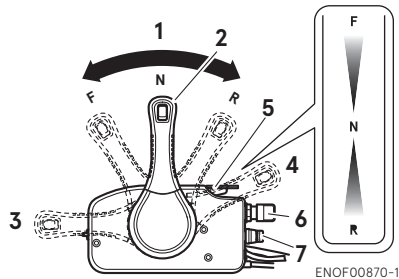

ENOF00870-1

1. Neutral (N)
2. Control lever
3. Fully opened (Forward)
4. Fully opened (Reverse)
5. Free throttle lever
6. Main switch key
7. Stop switch

ENON00035-1

**Note**

The free throttle lever cannot be raised when the control lever is in Forward or Reverse.

4. Turn the main switch key to ON position.
5. Turn the main switch key to START position and release the key when the engine has started. Also, confirm warning lamp light up with beep sound and then lights out. The key returns to the original position, automatically.

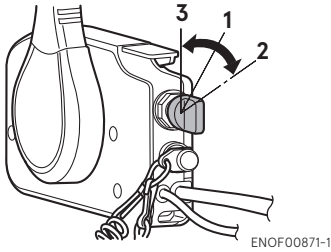

1. ON
2. START
3. OFF

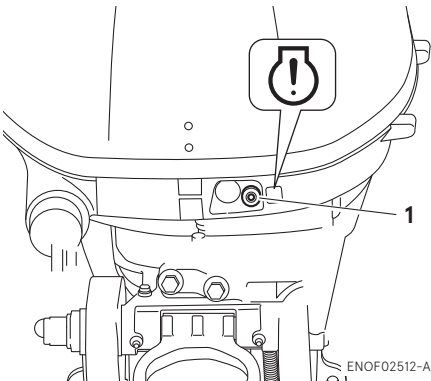

1. Warning lamp

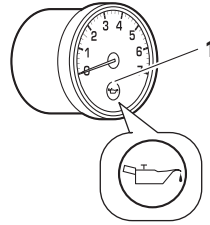

ENOF00851-A

1. Warning lamp

ENON00035-1

**Note**

The free throttle lever cannot be raised when the control lever shift is in Forward or Reverse.

6. Make sure that water is being discharged from the cooling water check port.

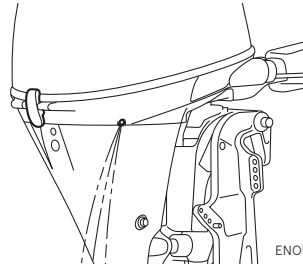

ENOM00042-A

**Emergency starting**

ENOW00099-1



When the emergency starter rope is used for starting engine;

- Start in gear protection does not work. Make sure that shift is in neutral position. If the gear is in Forward or Reverse, the boat can start moving immediately and may lead to accident and personal injury.
- Be careful that of your clothes or other items do not to get caught in the rotating parts.
- To prevent accident and injury by rotating parts, do not re-attach flywheel cover

and the top cowl after the engine has been started.

- Do not pull starter rope if any bystander is around.
- Attach engine stop switch lanyard to clothing or any part of body such as wrist, arm before starting engine the outboard motor.

1. Remove the top cowl.

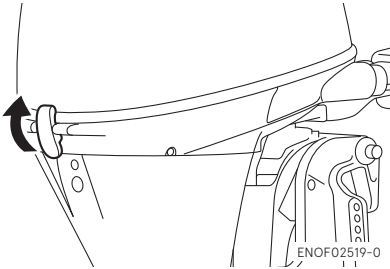

2. Remove starter lock cable from recoil starter by pulling the starter lock cable.

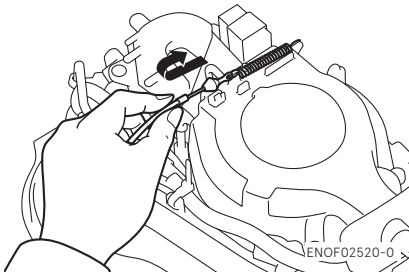

3. Remove the bolts (3 pcs) and remove the recoil starter.

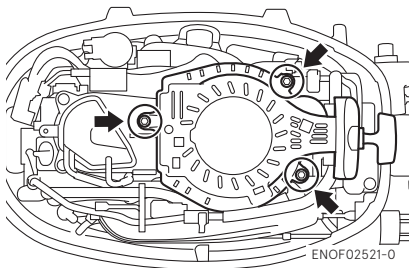

4. Insert the knotted end of the starter rope into the notch in the flywheel and wind the rope clockwise around the flywheel several turns.

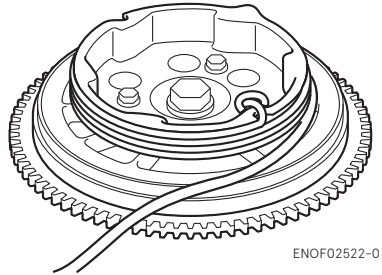

5. Tie a loop in the another end of the emergency starter rope and attach socket wrench, Both the loop and the wrench are provided in outboard motor box.

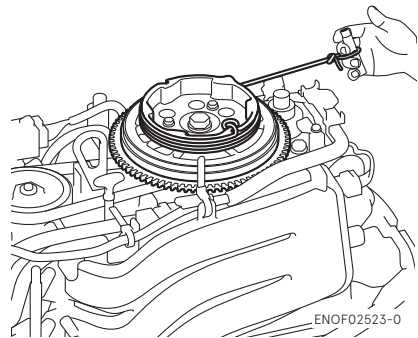

ENOW00860-0

### ⚠ CAUTION

Be sure to keep the harness away from the rotation parts.

6. Be sure to install the stop switch lock to the stop switch, and attach the stop switch lanyard securely to the operator or to the operator's PFD (Personal Flotation Device.)

7. Set the control lever in the Neutral position.
8. Pull the starter handle slowly until you feel engagement, keep pulling till you feel less resistance. Then pull it quickly.
9. Once the outboard motor is started, do not reinstall the recoil starter and top cowl.

ENOM00043-A

### 3. Warming up the engine

ENOW00932-1

#### **CAUTION**

**Be sure to check that cooling water is discharged from the cooling water check port during warm up.**

7

Warm the engine at low engine speeds for about

3 minutes : above 5°C (41°F)

5 minutes at 2000 min<sup>-1</sup> (rpm) : below 5°C (41°F)

This allows the lubricating oil to circulate to all parts of the engine. Operating the engine without warm up shortens the engine's life.

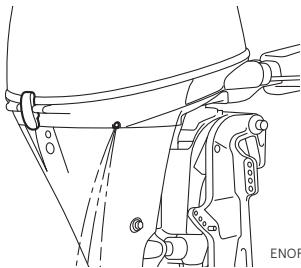

ENOF02518-0

ENOM01826-0

### Engine speeds

Idling speed after warming up.

Remark: The idling speed automatically increases depending on the engine temperature. When the engine reaches normal operating temperature, it will return to the specified idling speed.

Clutch in (In gear)	Clutch off (Out of gear)
850 min <sup>-1</sup> (rpm)	850 min <sup>-1</sup> (rpm)

ENOM00972-0

### Free throttle lever (Side mount RC type)

ENOW00956-0

#### **CAUTION**

- Keep the free throttle lever fully closed-position when start the engine.
- The free throttle lever is inoperative unless the control lever is in neutral.
- Also, the control lever is inoperative unless the free throttle lever is returned to the fully-closed position.

The free throttle lever is for warm-up operation.(Not required for engine starting) With the control lever in neutral, move the free throttle lever upward to open the throttle.

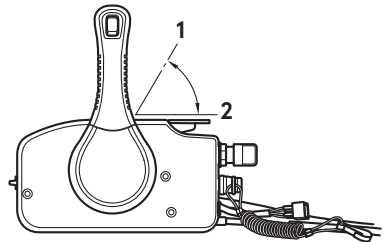

ENOF00934-0

1. Fully-open
2. Fully-closed

ENOM00880-A

### Trolling speed control

If the main switch key (for basic tiller handle model: Push switch) is pressed for 1 (one) second during idling or trolling operation, engine speed changes.

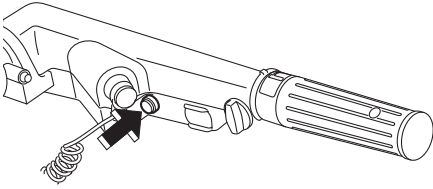

ENOF02540-0

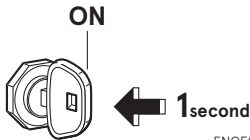

ENOF00876-0

each time the main switch key is pressed. Engine speed changes as follows.

#### Starting

850 min<sup>-1</sup> (rpm) → 750 min<sup>-1</sup> (rpm)



950 min<sup>-1</sup> (rpm)      850 min<sup>-1</sup> (rpm)



1050 min<sup>-1</sup> (rpm) ← 950 min<sup>-1</sup> (rpm)

Buzzer makes one short sound when the engine speed is set to 750 min<sup>-1</sup> (rpm), indicating the minimum trolling speed is set.

Buzzer makes two short sound when the engine speed is set to 1,050 min<sup>-1</sup> (rpm), indicating the maximum trolling speed is set.

Trolling speed control function will reset

and trolling speed is set to 850 min<sup>-1</sup> (rpm) when the engine speed is increased above 3,000 min<sup>-1</sup> (rpm) or after the engine restarted.

If battery voltage is lower than specified value, this function does not operate, and trolling speed is controlled to 850 min<sup>-1</sup> (rpm) automatically.

ENOW00046-A

## 4. Forward, reverse, and acceleration

ENOW00037-1

### ⚠ WARNING

Before shifting into forward or reverse, make sure that boat is properly moored and outboard motor can be steered fully to the right and left. Make sure that no swimmer(s) is around of the boat.

ENOW00967-0

### ⚠ WARNING

- Attach the other end of emergency stop switch lanyard to the operator's PFD (Personal Flotation device) or arm and keep it attached during cruising.
- Do not attach the lanyard to a part of clothing that can be torn easily when pulled.
- Arrange the lanyard so that will not be caught by any object when pulled.
- Be careful not to pull the lanyard accidentally during cruising. Unintentional stop of engine can cause loss of control of outboard motor. Rapid loss of engine power can lead to fall down or causing passenger(s) to be thrown overboard.

ENOW00042-1

**WARNING**

- Do not shift into Reverse during planing, or control will be lost leading to serious personal injury, boat may swamp, and/or hull may be damaged.
- Do not shift into Reverse during cruising, or control may be lost, fall down or causing passenger(s) to be thrown overboard. Leading to serious personal injury, and steering system and/or shifting mechanism may be damaged.

ENOW00861-1

**WARNING**

Do not shift at high boat speed, or control may be lost, fall down or causing passenger(s) to be thrown overboard. Leading to serious personal injury.

ENOW00867-1

**WARNING**

Sudden acceleration and deceleration may cause passenger(s) to be thrown overboard or fall down.

ENOW00862-1

**CAUTION**

Gear and clutch damage may occur if shifting at high engine speed.  
Engine must be in the slow idle position before shifting.

ENOW00863-0

**CAUTION**

Idle speed may be higher during warming up of engine. If shifted to Forward or Reverse during warming up, it may be difficult to shift back to neutral. In such case, stop engine, shift to neutral, and restart engine to warm up.

ENON00014-0

**Note**

Frequent shifting to forward or reverse can accelerate wear or degradation of parts. In such case, replace gear oil earlier than the period specified.

ENOW00864-0

**CAUTION**

Do not increase engine speed unnecessarily when the shift is in neutral and reverse, or engine damage may occur.

ENOM00890-A

**Tiller handle type**

ENOW00865-0

**CAUTION**

Do not force to shift when the throttle grip is not in the fully closed position, otherwise, steering system and/or shifting mechanism may be damaged. The control lever is inoperative unless the throttle grip is in the fully closed position. (Multi-function tiller type)

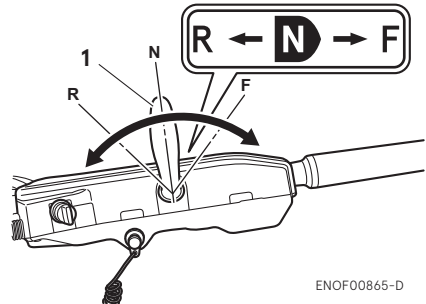

1. Shift lever

ENOF00865-D



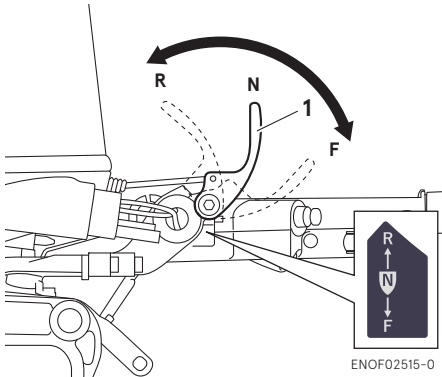

1. Shift lever

ENOF02515-0

**Forward**

1. Turn the throttle grip to reduce engine speed.
2. When the engine reaches troling (or idling) speed, quickly shift the lever into the Forward (F) position.

**Reverse**

1. Turn the throttle grip to reduce engine speed.
2. When the engine reaches troling (or idling) speed, quickly shift the lever into the Reverse (R) position.

**Acceleration**

Open throttle grip gradually.

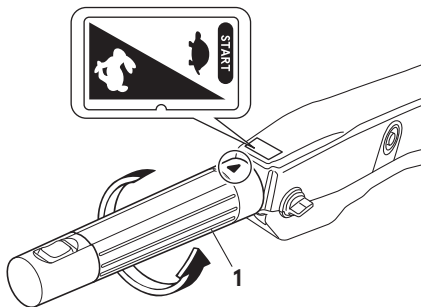

1. Throttle grip

ENOF00878-2

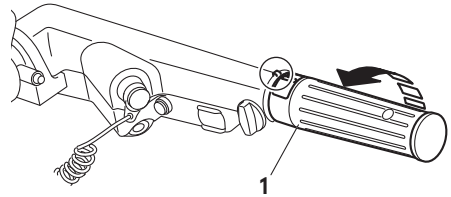

1. Throttle grip

ENOF02524-0

ENOM0900-A

**Side mount RC type**

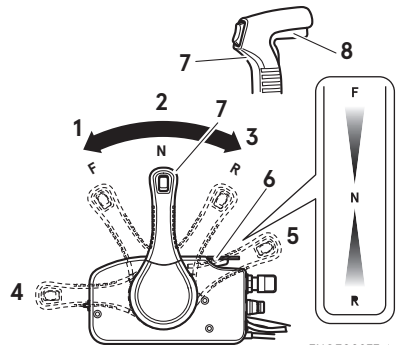

ENOF00877-1

1. Forward (F)
2. Neutral (N)
3. Reverse (R)
4. Fully opened (Forward)
5. Fully opened (Reverse)
6. Free throttle lever
7. Control lever
8. Neutral lock arm

**Forward**

1. Quickly shift the control lever into Forward (F) position at 32°, where the gear is connected, while lifting up on the neutral lock arm located under the control lever grip.
2. Further forward motion will open the throttle.

**Reverse**

1. Quickly shift the control lever into reverse (R) position at 32°, where the gear will be connected, while lifting up the neutral lock arm located under the control lever grip.
2. Further rearward motion will open the throttle.

**Acceleration**

Open throttle grip or control lever gradually.

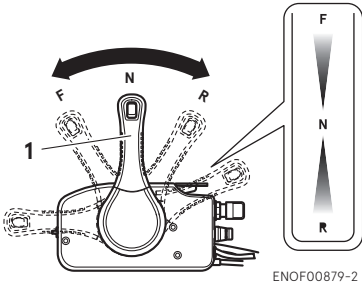

ENOF00879-2

1. Control lever

ENOM01904-0

**5. Stopping the engine**

ENOW00868-1



**Be careful not to remove engine stop switch lanyard from engine accidentally while boat is running. Sudden stop of engine can cause loss of steering control, speed, possibly leading the crew(s) and or objects on the boat to be thrown forward due to inertial force.**

**Tiller handle type**

1. Turn the throttle grip to the slow position.

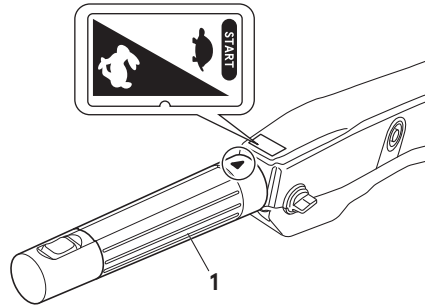

ENOF00866-2

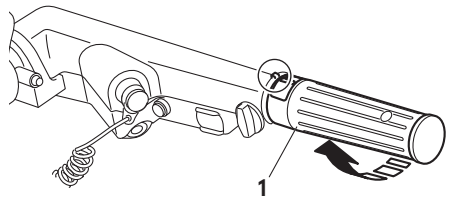

ENOF02516-0

1. Throttle grip
2. Put the shift lever in the Neutral position.  
Run the engine for 2-3 minutes at idling speed for cooling down if it has been running at full speed.

### Basic tiller handle type

1. Push the stop switch for a few seconds to stop the engine.

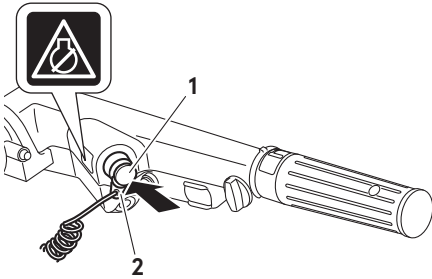

ENOF02542-0

1. Stop switch
2. Stop switch lock

### Multi-function tiller handle type

3. Turn the main switch key to the OFF position.
4. Push the stop switch for a few seconds to stop the engine.
5. Turn the main switch key to the OFF position or push the stop switch. ( Do not forget to turn the key off).

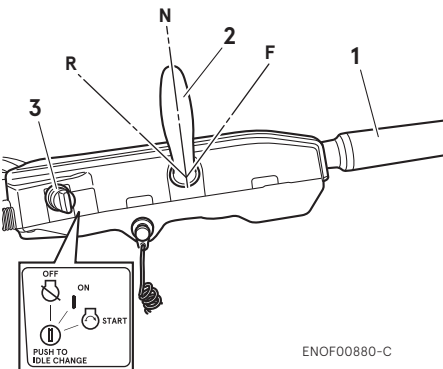

ENOF00880-C

1. Throttle grip
2. Shift lever
3. Main switch key

### Side mount RC type

1. Put the control lever in the Neutral position and run the engine for 2-3 minutes at idling speed for cooling down if it has been running at full speed.

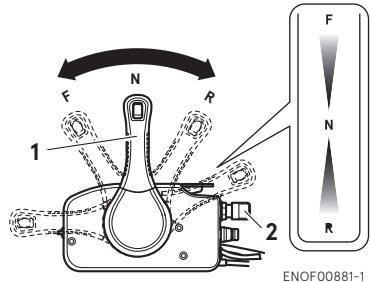

ENOF00881-1

1. Control lever
  2. Main switch key
2. Turn the main switch key to the OFF position.

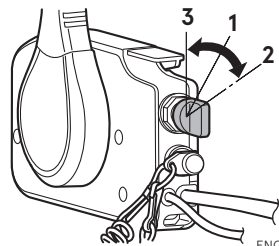

ENOF00871-1

1. ON
2. START
3. OFF

ENOW00869-1

### ⚠ WARNING

After stopping the engine:

- Close the air vent screw on the fuel tank cap.
- Disconnect the fuel connector from the engine and the fuel tank.
- Disconnect the battery cable, after each use.

**Emergency engine stopping**

Remove stop switch lock to stop the engine.

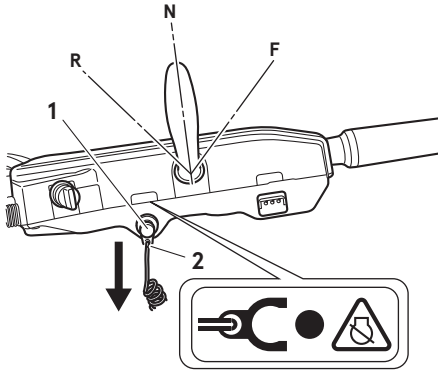

ENOF00883-2

- 1. Stop switch
- 2. Stop switch lock

7

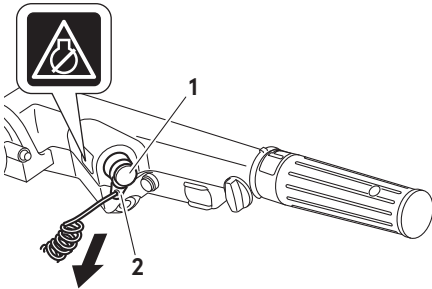

ENOF02543-0

- 1. Stop switch
- 2. Stop switch lock

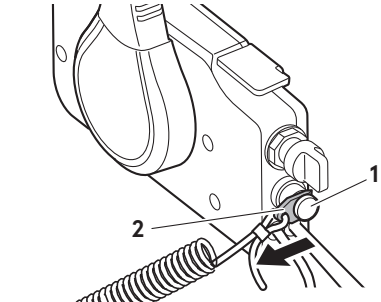

ENOF00869-A1

- 1. Stop switch
- 2. Stop switch lock

ENOM00910-1

**Spare emergency stop switch lock (For CE marking model)**

A spare emergency stop switch lock is provided in the accessories bag.

Make sure that spare stop switch lock is available before operating outboard motor.

When used as described, the emergency stop switch clip and emergency stop switch lanyard system stops the engine if the operator is thrown overboard. When an operator falls into water, be sure to use spare emergency stop switch lock.

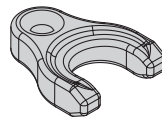

ENOF00891-0

ENOM00920-0

## 6. Steering

ENOW00870-1

### WARNING

Sudden steering may cause passenger(s) to be thrown overboard or fall.

### Tiller handle type

#### Right turn

Move the tiller handle to the left

#### Left turn

Move the tiller handle to the right.



ENOF00892-0

### Remote control type

#### Right turn

Turn the steering wheel to the right.

#### Left turn

Turn the steering wheel to the left.

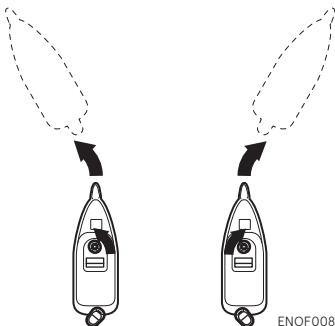

ENOF00893-0

ENOM00050-0

## 7. Trim angle

ENOW00043-1

### WARNING

- Adjust the trim angle when the engine is stopped.
- Do not put hand or finger in between outboard motor body and clamp bracket when adjusting trim angle to prevent possible injury.
- Unsuitable trim position can cause loss of control of boat. When testing a trim position, run the boat slowly initially to see if it can be controlled safely.

ENOW00044-1

### WARNING

Excessive trim up or down may cause unstable boat operation, loss of control that may leads to accident during cruising.

- For manual tilt model, If you feel the trim is improperly positioned, stop the boat and readjust trim angle before continuing to cruise.
- For outboard motor model with PT or PTT switch on the bottom cowl, do not operate the switch during while cruising, or control of boat may be lost.

The trim angle of the outboard motor can be adjusted to suit the transom angle of the hull, and load conditions. Choose an appropriate trim angle that will allow the anti-ventilation plate to run parallel to the water surface during operation.

ENOM00052-0

**Proper trim angle**

The position of the thrust rod is correct if the hull is horizontal during operation.

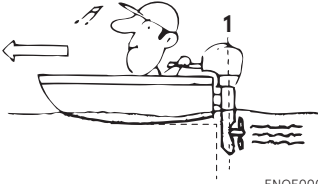

ENOF00051-1

- 1. Perpendicular to the water surface

ENOM00053-0

**Improper trim angle (bow rises too high)**

Set the thrust rod lower if the bow of the boat rises above horizontal.



ENOF00052-0

ENOM00054-0

**Improper trim angle (bow dips into the water)**

Set the thrust rod higher if the bow of the boat is below horizontal.



ENOF00053-0

■ Manual Tilt type

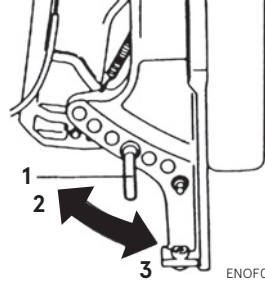

ENOF00674-B

- 1. Thrust rod
- 2. Higher
- 3. Lower

■ Power Tilt type

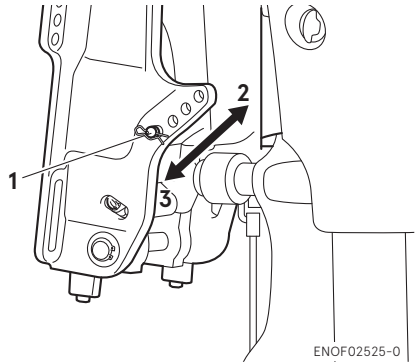

ENOF02525-0

- 1. Thrust rod
- 2. Higher
- 3. Lower

**Trim angle adjustment (Manual tilt type)**

The transom angle adjustment

1. Stop the engine.
2. Shift into neutral position.
3. Tilt up the outboard motor.
4. Remove the thrust rod as shown picture.

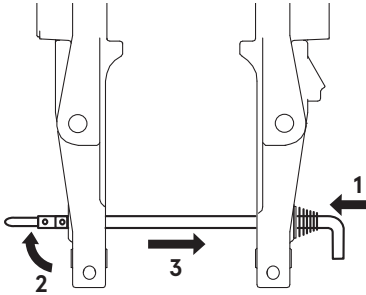

ENOF01238-1

1. Push in
2. Rise the stopper
3. Pull out
5. Reinstall the thrust rod in the desired position securely.
6. Gently tilt down the outboard motor.

**Trim angle adjustment (Power tilt type)**

The transom angle adjustment

1. Stop the engine.
2. Shift into neutral position.
3. Tilt up the outboard motor.
4. Lock the tilt stopper.

5. Remove the Snap pin and Thrust rod as shown in the picture.

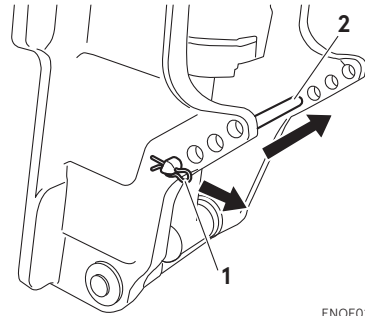

ENOF01147-0

1. Snap pin
2. Thrust rod
6. Reinstall the thrust rod in the desired position securely.
7. Put the Snap pin back and unlock the tilt stopper.
8. Gently tilt down the outboard motor.

ENOM00060-A

**8. Tilt up and down**

ENOW00055-1

**! WARNING**

**Do not tilt the outboard motor up or down when swimmer(s) and/or passenger(s) are near to prevent them from being caught between outboard motor body and clamp bracket.**

ENOW00048-1

**! WARNING**

**When tilting up or down, be careful not to place your hand between the swivel bracket and the stern bracket.**

ENOW00056-A

**WARNING**

When tilting up outboard motor with fuel joint for over a few minutes, be sure to disconnect fuel hose, or fuel may leak, potentially catching fire.

ENOW00057-1

**CAUTION**

Do not tilt up the outboard motor while engine is operating, or no cooling water may be discharged, leading to engine seizure due to overheating.

ENOM00921-1

**Note**

After use, leave the outboard motor upright for a minute to drain the water from inside the engine.

7

ENOM00062-1B

**Manual Tilt type****Tilt up**

Push the reverse lock lever down until it stops. (This is the tilt up position.) Then, tilt the outboard motor all the way up until it is locked in place.

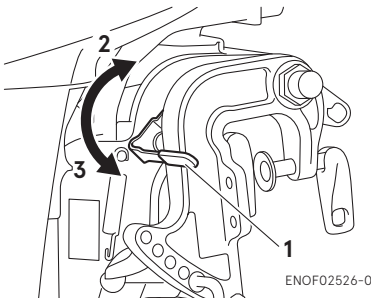

1. Reverse lock lever
2. Tilt down position
3. Tilt up position

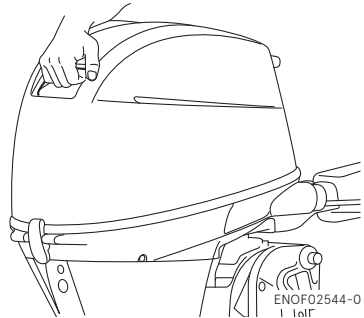

ENOM00063-1

**Tilt down**

Pull the reverse lock lever upward until it comes to a stop (This is the tilt down position), lift up the outboard motor to free it from the reverse lock, then release to lower the outboard motor.

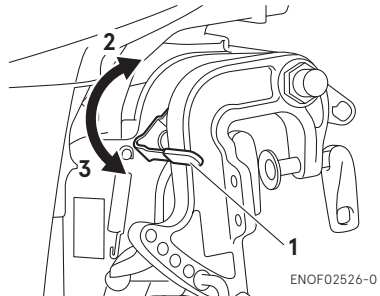

1. Reverse lock lever
2. Tilt down position
3. Tilt up position

ENOM00069-B

**Power Tilt type****Tilt up**

1. Operate the Power Tilt switch and tilt the outboard motor up.
2. Lock the tilt with the Tilt stopper after the outboard motor has been tilted up



**Tilt down**

1. Release the tilt stopper from the set-up position while slightly tilting up outboard motor.
2. Operate the Power Tilt switch and tilt the outboard motor down until the motor touches to the thrust rod.

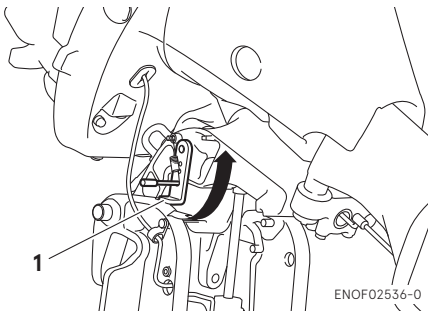
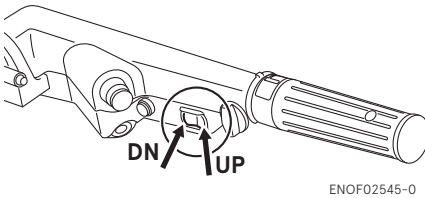
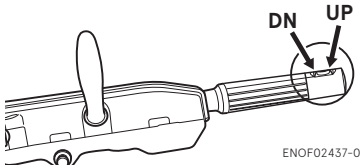
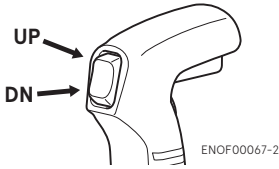

1. Tilt stopper

The outboard motor can also be tilted up and down using the switch provided on the bottom cowl.

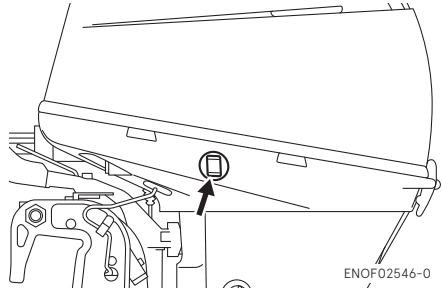

It is possible to tilt up or down whether or not the main switch is "ON" or "OFF".

ENOM00940-1

**Manual relief valve**

If the battery is dead, and/or the power tilt switch is inoperative open the manual relief valve completely in the Manual direction. This allows the outboard motor to be tilted manually.

ENOW00872-1



**Make sure the manual relief valve is closed before operating the outboard motor. If the manual relief valve is not closed, the outboard motor will be tilted up when shifting in reverse.**

ENOW00873-1



**Before opening the manual relief valve, make sure nobody is under the outboard motor. If the outboard motor is in the tilted up position with the manual relief valve loosend, the outboard motor will be tilted down suddenly.**

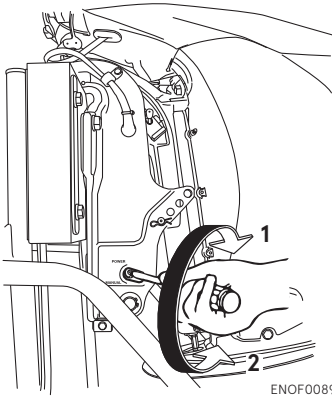

ENOF00892-0

- 1. Power
- 2. Manual

Manual relief valve specified tightening torque

**2 N·m (1.5 ft·lb, 0.2 kgf·m)**

7

ENOM00068-A

## 9. Shallow water operation

ENOW00051-0

### ! WARNING

During shallow water operation, be careful not to place your hand between the swivel bracket and the clamp bracket. Be sure to tilt the outboard motor down slowly.

ENOW00053-0

### ! CAUTION

While in shallow water drive position, do not operate the outboard motor in Reverse. Operate the outboard motor at slow speed and keep the cooling water intake submerged.

ENOW00054-1

### ! CAUTION

Do not over tilt the outboard motor when driving in shallow water, or air may be sucked through water inlet and sub-water inlet, potentially leading to engine overheating.

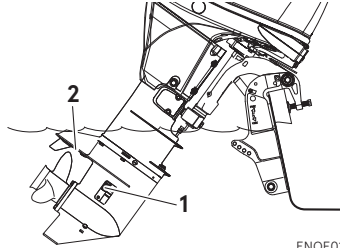

ENOF01144-0

- 1. Water inlet
- 2. Sub-water inlet

## Manual tilt type

1. Shallow water running position:  
Put the reverse lock lever in the tilt up position, and tilt up the outboard motor to put the outboard motor in the shallow water running position.

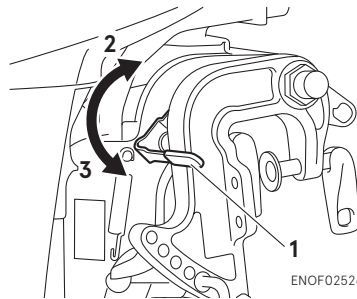

ENOF02526-0

- 1. Reverse lock lever
- 2. Tilt down position
- 3. Tilt up position

- Return to normal running position:  
Put the reverse lock lever in the tilt down position, slightly lift up the outboard motor, and then put it down.

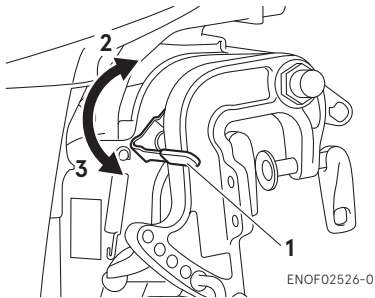

- Reverse lock lever
- Tilt down position
- Tilt up position

ENOM00069-A

### Power Tilt type

- Operate the Power Tilt switch and tilt the outboard motor up into desired shallow water running position.

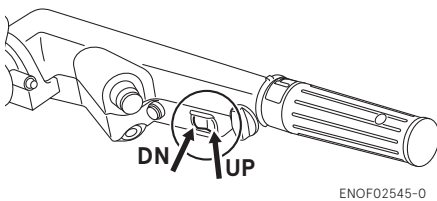
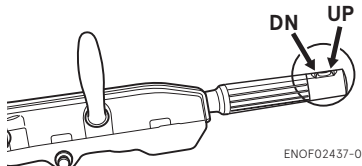
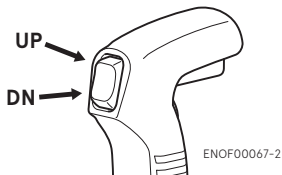

# REMOVING AND CARRYING THE OUTBOARD MOTOR

ENOM00070-A

## 1. Removing the outboard motor

ENOW00890-0

### ⚠ WARNING

Before installing the outboard motor on the boat, hang the outboard motor with the hoist or equivalent device by attaching the engine hanger to the outboard.

Use the hoist with allowable load is 150 kg (330 lbs) or above.

ENOW00064-1

### ⚠ CAUTION

Engine may be hot immediately after operation and could cause burns if came in contact. Allow engine to cool down before attempting to carry the outboard.

1. Stop the engine.
2. Remove the top cowl.
3. Disconnect the fuel connector, the remote control cables and the battery cords from the outboard motor.
4. Attach the hoist hooks to the engine hanger.
5. Remove the outboard motor from boat and completely drain the water from the gear case.

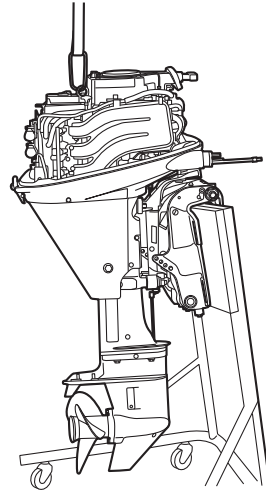

ENOF02508-0

ENOM00071-A

## 2. Carrying the outboard motor

ENOW00933-0

### ⚠ WARNING

Be sure to disconnect fuel connector except when operating engine.

Fuel leakage is a fire or explosion hazard, which can cause serious injury or death.

ENOW00065-1

### ⚠ WARNING

Close air vent screw on fuel tank before carrying or storing outboard motor and fuel tank, or fuel may leak, potentially catching fire.

ENOW00066-1

### ⚠ CAUTION

- Do not give a shock to an outboard motor during transportation.
- Do not carry or store outboard motor in any of positions described below.

Otherwise, engine's exterior may be damaged or water may enter the cylinder through the exhaust port and cause engine problems.

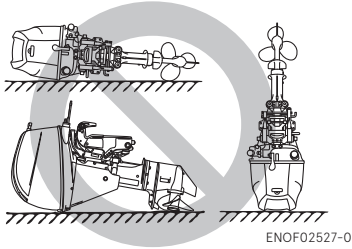

Keep the outboard motor in a vertical position when carrying. The optional outboard motor stand is recommended for keeping the outboard motor vertical both during transport and storage.

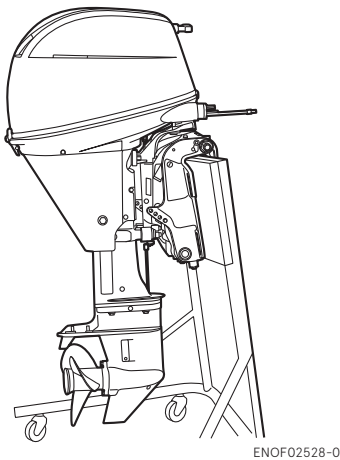

ENON00021-3  
**Note**

If the outboard motor must be laid down, be sure that fuel is completely drained, then lay the outboard motor with port side

down on the cushion as shown in the drawing.

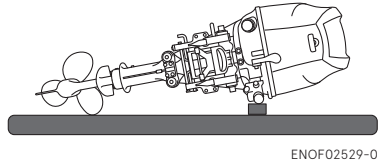

ENOM00072-1A

### 3. Trailering

ENOW00072-0

**CAUTION**

Trailering in the tilted position may cause damage to the outboard motor, boat, etc.

ENOW00073-A

**WARNING**

Be sure to disconnect fuel connector except when operating engine. Fuel leakage is a fire or explosion hazard, which can cause serious injury or death.

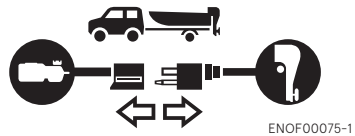

ENOW00068-0

**WARNING**

Close air vent screw on fuel tank and fuel cock before carrying or storing outboard motor and/or fuel tank, or fuel may leak, potentially catching fire.

ENOW00071-0

## ⚠ CAUTION

**The tilt support device supplied on your outboard motor is not intended for towing. It is intended to support the outboard motor while the boat is docked, beached, etc.**

When transporting a boat on a trailer with the outboard motor attached, disconnect the fuel line from the outboard motor beforehand and keep the outboard motor in the vertical or on a transom saver bar.

### Tiller handle type

While transporting outboard motor attached to the boat on a trailer, properly tighten the steering friction bolt to prevent the outboard motor from moving. (page 63).

8

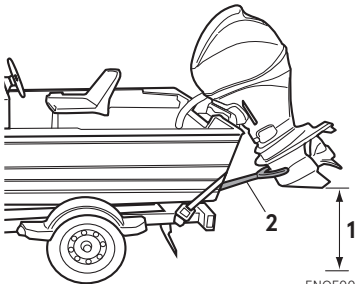

ENOF00074-A

1. Ground clearance should be provided sufficiently.
2. Transom saver bar

ENOW00067-0

## ⚠ WARNING

**Do not go under outboard motor tilted up even if it is supported by support bar, or accidental fall of outboard motor could lead to severe personal injury.**

# ADJUSTMENT

ENOM00073-0

## 1. Steering friction

### Tiller handle type

ENOW00074-1

#### **! WARNING**

**Do not overtighten the steering friction lever, it could result in difficult handling of the outboard motor, resulting in the loss of control causing an accident and could lead to severe injury.**

Adjust this lever to achieve the desired steering friction (drag) on the tiller handle. Move lever towards (2) to decrease friction and move lever towards (3) to increase friction.

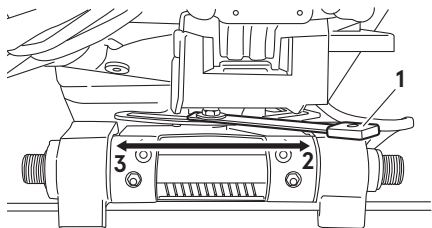

ENOF00910-0

1. Steering friction lever
2. Decrease
3. Increase

ENOM00074-A

## 2. Throttle grip friction

ENOW00074-1B

#### **! WARNING**

**Do not overtighten the throttle adjustment screw or it could result in difficult handling of the outboard motor, resulting in the loss of control causing an accident and could lead to severe injury.**

Friction adjustment of the throttle grip can be made with the throttle adjustment screw.

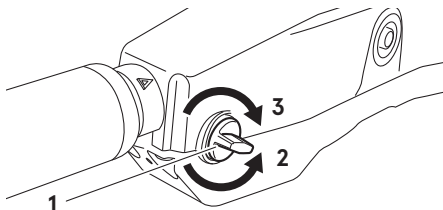

ENOF00911-1

1. Throttle friction adjustment screw
2. Decrease
3. Increase

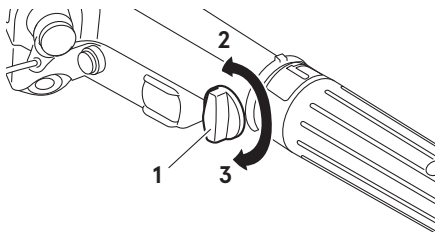

ENOF02547-0

1. Throttle friction adjustment screw
2. Decrease
3. Increase

ENOM00075-0

## 3. Remote control lever friction

9

ENOW00074-1C

#### **! WARNING**

**Do not overtighten the remote control throttle friction adjustment screw or it could result in difficult handling of the outboard motor, resulting in the loss of control causing an accident and could lead to severe injury.**

To adjust the friction of the remote control lever, turn the throttle friction adjustment screw on the front of the remote control. Turn clockwise to increase the friction and counter-clockwise to decrease it.

### Side mount type

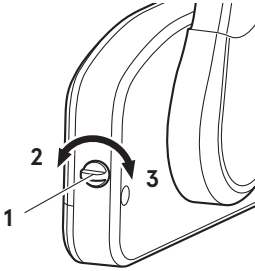

ENOF00078-2

1. Throttle friction adjustment screw
2. Decrease
3. Increase

ENOM00076-0

## 4. Trim tab adjustment

ENOW00076-1

### ! WARNING

- Be sure that the outboard motor is secured to transom or service stand, or accidental drop or fall of outboard motor could lead to severe personal injury.
- Be sure to lock the outboard motor in the tilt up position, or accidental fall of outboard motor could lead to severe personal injury.
- Do not go under outboard motor in the tilt up position and locked, or accidental fall of outboard motor could lead to severe personal injury.

ENOW00075-1

### ! WARNING

Inappropriate adjustment of trim tab could cause steering difficulty. After installing or readjusting trim tab, check if steering load is even.

If straight-line cruising can not be achieved, adjust the trim tab located under the anti-ventilation plate.

- If the boat veers toward the left direct the trim tab towards A (left from rear of boat).
- If the boat veers toward the right direct the trim tab towards B (right from rear of boat).

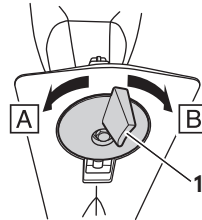
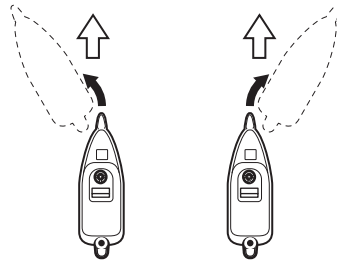

ENOF02449-0

1. Trim tab

ENON00022-A

### Notes

- After adjustment securely tighten the trim tab fixing bolt.
- Check for looseness of the bolt and the trim tab at regular intervals.



ENOM01903-0

## 5. Multi-function tiller handle angle adjustment

ENOW00985-0

### WARNING

- Do not install or remove spacers on the bracket with engine running.
- Do not install more than 6 spacers [ 1 ].

The angle of the multi-function tiller handle can be adjusted between 0 and 30 degrees by using the spacer kit that comes with the multi-function tiller handle.

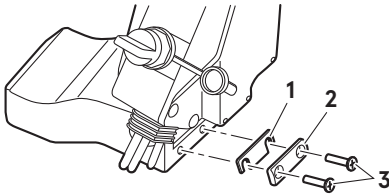

ENOF02550-0

1. Spacer [1]
2. Spacer [2]
3. Screw

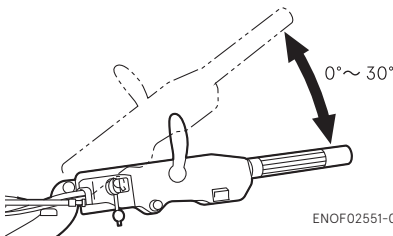

ENOF02551-0

### ■ Angle of Multi-Function Tiller Handle according to the number of spacers.

Spacer [1] (Qty)	Spacer [2] (Qty)	Angle (approx)
0	0	0°
0	1	9.5°
1	1	14°
2	1	20.5°
3	1	23.5°
4	1	27°
5	1	30°

After adjusting the angle, fully turn the tiller handle to both side and check that there is no problem in operation.

ENON00022-A

### Notes

- Tighten the screws securely.
- Periodically make sure that the bolts are not loose.
- The multi-function tiller handle kit includes one spacer [1], one spacer [2] and screws.

# INSPECTION AND MAINTENANCE

ENOM00077-1

## Care of your outboard motor

To keep your outboard motor in the best operating condition, it is very important that you perform daily and periodic maintenance as suggested in the maintenance schedules as follows.

ENOW00077-1

### CAUTION

- **Your personal safety and that of your passengers depends on how well you maintain your outboard motor. Carefully read all of the inspection and maintenance procedures described in this section.**
  - **The maintenance intervals shown in the checklist apply to an outboard motor in normal use. If you use your outboard motor under severe conditions such as frequent full-throttle operation, frequent operation in brackish water, or for commercial use, maintenance should be performed at shorter intervals. If in doubt, consult your dealer for advice.**
  - **We strongly recommend that you use only genuine replacement parts on your outboard motor. Damage to your outboard motor arising from the use of other than genuine parts is not covered under the warranty.**
-

ENOM00079-0

## 1. Daily Inspection

Perform the following checks before and after use.

ENOW00078-1

### WARNING

**Do not use outboard motor if any abnormality is found during pre-operation check otherwise it could result in severe damage to the motor or severe personal injury.**

Item	Points to Check	Remedy
<b>Fuel System</b>	<ul style="list-style-type: none"> <li>Check the amount of fuel in the tank.</li> <li>Check for debris or water in the fuel filters.</li> <li>Check the rubber hoses for fuel leakage.</li> </ul>	Replenish Clean or replace if necessary Replace if necessary
<b>Fuel Tank Cap</b>	<ul style="list-style-type: none"> <li>Check for crack, leakage, damage in the fuel tank cap.</li> <li>Check for crack, damage in the gasket.</li> <li>Check for leakage at full close.</li> </ul>	Replace if necessary Replace if necessary Replace if necessary
<b>Engine Oil</b>	<ul style="list-style-type: none"> <li>Check the oil level.</li> </ul>	Fill oil
<b>Electrical Equipment</b>	<ul style="list-style-type: none"> <li>Check that the main switch functions normally.</li> <li>Check that the battery electrolyte level and specific gravity are normal.</li> <li>Check for loose connections on the battery terminal.</li> <li>Check that the stop switch functions normally and make sure the stop switch lock is secured.</li> <li>Check cords for loose connections and damage.</li> <li>Check the spark plugs for dirt, wear and carbon build-up.</li> <li>Check the warning buzzer (one beep) and warning LED lamp (ON for 1 sec.) when start up.</li> </ul>	Replace if necessary Replenish or recharge Retighten Remedy or replace if necessary Correct or replace if necessary Clean or replace if necessary Repair
<b>Recoil starter</b>	<ul style="list-style-type: none"> <li>Check the rope for wear and chafing.</li> <li>Check the ratchet engagement.</li> </ul>	Replace if necessary Replace if necessary
<b>Clutch and Propeller System</b>	<ul style="list-style-type: none"> <li>Check that clutch engages correctly when operating the shift lever.</li> <li>Visually Check propeller for bent or damaged blades.</li> <li>Check the propeller nut is tightened and the split pin is in correct position.</li> </ul>	Adjust Replace if necessary Tighten or replace
<b>Installation of Motor</b>	<ul style="list-style-type: none"> <li>Check all the bolts attaching the motor to the boat.</li> <li>Check the thrust rod installation.</li> </ul>	Tighten Replace if necessary
<b>Power Tilt</b>	<ul style="list-style-type: none"> <li>Check working of the tilt up and down of the motor.</li> </ul>	Repair
<b>Cooling Water</b>	<ul style="list-style-type: none"> <li>After starting the outboard motor, make sure that water is being discharged from the cooling water check port.</li> </ul>	Repair
<b>Tools and Spares</b>	<ul style="list-style-type: none"> <li>Check that there are tools and spare parts for replacing spark plugs, the propeller, etc.</li> <li>Check that you have the spare rope and stop switch lock.</li> </ul>	Order Order

Item	Points to Check	Remedy
<b>Steering Devices</b>	· Make sure that steering handle and remote control is functioning normally.	Repair
<b>Other parts</b>	· Check if the anode is securely installed. · Check the anode for corrosion and deformation.	Repair if necessary Replace

ENOM01905-0

### Oil level checking

If the oil level is low, or too high, the life of the engine will be shortened significantly.

1. Stop the engine and place the out-board motor in a vertical position.
2. Pull the bottom of cowl latch to unlock, lift and remove the top cowl.
3. After the engine has been shut off 5 minutes, remove the dipstick and wipe oil off with a clean cloth.
4. Insert the dipstick to the hole completely.
5. Remove the dipstick. Oil level must be between the upper limit and lower limit shown on the dipstick.
6. If the oil level is below the lower limit, add the oil to between the upper and lower limit mark on the dipstick.

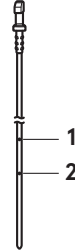

ENOF02511-0

1. Upper limit
2. Lower limit

ENON00024-0

#### Note

The oil level should be checked when the engine is cooled.

ENON00025-0

#### Note

Consult with an authorized dealer if the engine oil is milky color, or appears contaminated.

10

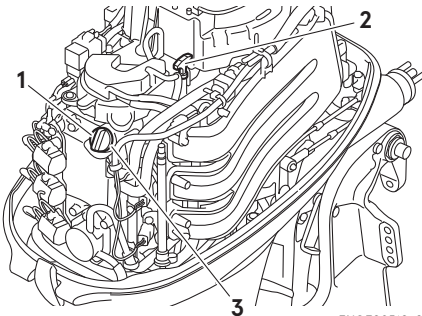

ENOF02510-0

1. Filler cap
2. Dipstick
3. Filler port

ENOM00082-A

### Engine oil replenishing

ENOW00079-A

**⚠ CAUTION**

- Do not add engine oil of brand and grade other than existing one. In case engine oil of other brand or grade is added, drain all oil and ask dealer for treatment.
- In case other than engine oil such as gasoline is put in the oil chamber, empty the chamber and ask dealer for treatment.
- When replenishing engine oil, be careful not to allow entry of foreign matters such as dust and water into oil chamber.

- Wipe off engine oil well immediately if spilled and dispose of it in accordance with local fire prevention and environment protection regulations.
- Do not replenish engine oil over upper limit. If overfilled, remove oil to upper limit. If engine oil is over the upper limit, it can leak potentially leading to engine damage.

If the oil level is low, or at lowest mark, add recommended oil to the middle dipstick mark.

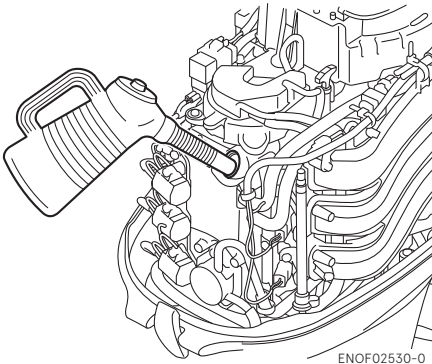

ENOM00083-B

## Washing outboard motor

ENOW00920-0

### ⚠ CAUTION

When washing the outboard motor, be careful not to spray the water inside of the top cowl, especially electrical components.

ENON00026-0

### Note

It is recommended to check chemical properties of water on which your outboard motor is regularly used.

If outboard motor is used in salt water, brackish water or water with high acidic level, use fresh water to remove salt, chemicals or mud. And flush cooling water passage after every use or before storing outboard motor for long time. Before flushing, remove the propeller and the forward thrust holder.

ENOM01903-0

## Gear case flushing device

ENOW00082-0

### ⚠ WARNING

Never start or operate the engine indoors or in any space which is not well ventilated. Exhaust gas contains carbon monoxide, a colorless and odorless gas which can be fatal if inhaled for any length of time.

ENOW00986-0

### ⚠ CAUTION

Never leave the outboard motor unattended while running on the flushing device. When the flushing device slip off from the gear case, the engine will overheat and may cause serious damage.

1. Fully tilt down the outboard motor.
2. With the propeller removed, seal the sub-water inlet with a tape to prevent air from being sucked into the water pump.

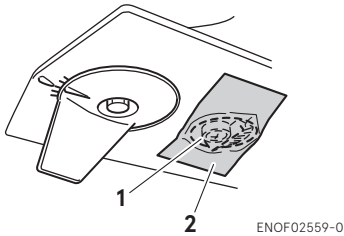

1. Sub-water inlet
2. Tape

3. Install the gear case flushing device on gear case so that the rubber cups cover the cooling water inlets tightly.
4. Connect a water hose to the flushing device and turn on the water and adjust the flow so that excess water continues leaking out from around the rubber cups to ensure the engine is receiving an adequate supply of cooling water.

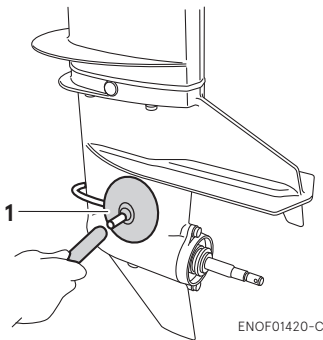

1. Gear case flushing device

5. Place the shift lever in the neutral position and start the engine and run at idle speed for 3-5 minutes.
6. Check if a steady stream of water flows from the cooling water check port.
7. Stop the engine and turn off the water. Remove the flushing device and tape. Install the propeller.
8. Leave the outboard motor in vertical position to completely drain the cooling water from the outboard motor.

ENOM00085-E

**Flushing hose joint**

ENOW00922-0

**⚠ CAUTION**

Do not operate the engine when flushing the outboard motor with a hose joint as this can cause damage to the outboard motor.

ENOW00922-0

**⚠ CAUTION**

To prevent the engine from starting when you are near the propeller, remove the stop switch lock.

1. Tilt down the outboard motor.
2. Remove the flushing connector cap from the outboard motor, and screw in the hose joint.
3. Connect a water hose. Turn on the water and adjust the flow.  
Continue flushing the outboard motor for 3 to 5 minutes
4. After the flushing, be sure to reattach the flushing connector cap.
5. Tilt up the outboard motor.

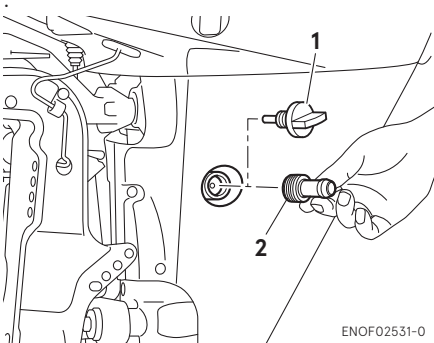

ENOF02531-0

1. Flushing connector cap
2. Hose joint

ENOM00085-A

**Flushing by test tank**

ENOW00081-1

**⚠ WARNING**

Do not start engine without removing propeller, turning propeller out in the open may lead to personal injury.

ENOW00082-0

**⚠ WARNING**

Never start or operate the engine indoors or in any space which is not well ventilated. Exhaust gas contains carbon monoxide, a colorless and odorless gas which can be fatal if inhaled for any length of time.

ENOW00036-1A

**⚠ CAUTION**

When starting the outboard motor in the test tank, make sure that:

1. Water level is at least 10 cm (4 in.) above the anti-ventilation plate to avoid overheating of the engine.
2. Run at idling only
3. Remove the propeller (See page 81)

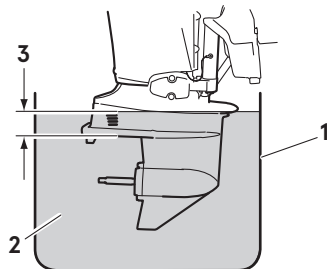

ENOF00863-0

1. Test tank
2. Water
3. Over 10 cm (4 in.)

ENOM00950-1

**Fuse replacement**

ENOW00923-1

**⚠ CAUTION**

**Before replacing a fuse, disconnect the battery cable from the battery negative (-) terminal first. Failure to properly remove battery cables may cause a short-circuit.**

ENOW00924-0

**⚠ CAUTION**

**Never use a fuse with a rating that exceeds the specified rating as this could cause serious damage to the electrical system.**

If the fuse is blown, try to determine the cause and respond to the problem as simply replacing the fuse will likely be blown again. If you are unable to respond to the cause or the fuse continues to blow, request an authorized Tohatsu dealer for inspection.

1. Stop the engine and disconnect the battery cable from the battery negative (-) terminal.
2. Remove the engine cover.
3. Remove the fuse box lid.

4. Remove the fuse for inspection. If the fuse is blown, replace it with a fuse of the same specified rating. The spare fuse is supplied with the outboard motor in the spare fuse holder.

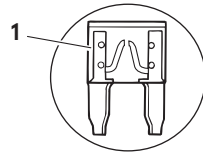
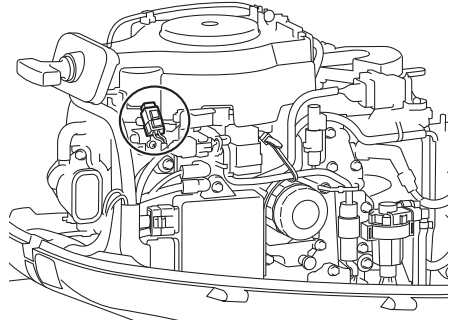

1. Blown fuse

ENOF02532-0



ENOM01106-1

## 2. Periodic Inspection

It is important to inspect and maintain your outboard motor regularly. Make sure to perform each service at interval specified in the chart below. Maintenance intervals are determined by the number of hours outboard motor has been used or number of months, whichever comes first.

Description		Inspection intervals					Inspection procedure	Remarks
		First 20 hours or 1 month	Every 50 hours or 3 months	Every 100 hours or 6 months	Every 200 hours or 1 year	Every 400 hours or 2 year		
Fuel System	Fuel filter			●/○			Check and clean / Replace if necessary.	
	Fuel filter (Vapor separator)					○	Check and clean / Replace if necessary.	
	High pressure fuel hose	●/○	●/○				Check / Replace if necessary.	
	Fuel tank	●/○	●/○				Check and clean.	
	Fuel tank cap	●/○	●/○				Check/Replace if necessary.	
	Fuel pump					○	Check/Replace if necessary.	
	Fuel pressure				○		Check	
	Hose	●/○	●/○				Check/Replace if necessary.	
Ignition System	Spark plug			●			Check and clean.	Gap 0.8-0.9 mm (0.031-0.035 in)
	Spark plug cap/ High tension cord	○		○			Check/Replace if necessary.	
Starting System	Starter rope	●/○	●/○				Wear check/ Replace if necessary.	
	Starter motor				○		Check (pinion)	
	Battery/Cable connection	○	○				Battery fluid level Check and Terminal loose.	
Engine	Engine oil	● Replace		● Replace			Replace	Approx 1500 mL (1.6/1.3 US/Imp. qt.) Oil filter replace 1700 mL (1.8/1.5 US/Imp. qt.)
	Oil filter (4 stroke)	○ Replace			○ Replace		Replace	
	Valve clearance				○		Check and adjust.	
	Timing belt				○		Check/Replace if necessary.	
	Compression pressure				○		Check	
	Thermostat				○		Check / Replace if necessary.	

\*"●" This procedure can be performed by end user.

\*"○" This procedure shall be carried out by the dealer.

Description		Inspection intervals					Inspection procedure	Remarks
		First 20 hours or 1 month	Every 50 hours or 3 months	Every 100 hours or 6 months	Every 200 hours or 1 year	Every 400 hours or 2 year		
Lower Unit	Propeller	●	●				Check/Replace if necessary.	
	Shear pin/Split pin	●	●				Check/Replace if necessary.	
	Gear oil	● Replace	●	● Replace			Change and replace.	Approx. 460 mL (15.6/16.2 US/ Imp. oz.)
	Water strainer	●	●				Check	
	Water pump impeller		●/○		○ Replace		Check/Replace if necessary.	
	Water pump housing					○	Check/Replace if necessary.	
Shift/ Throttle	Throttle cable			○			Check/Replace if necessary.	
	Throttle link	○	○				Check and adjust.	
	Shift cable		○				Check/Replace if necessary.	
	Shift link	○	○				Check and adjust.	
Power trim & tilt		●/○		●/○			Check and replenish.	
Warning system			○				Check	
Stop switch		●	●				Check	
Meters		○	○				Check	
Bolt, nut		○	○				Retighten	
Sliding part/rotation part		●	●				Apply grease and Pump in grease	
Grease nipple		●	●				Pump in grease	
Outer equipment		●	●				Check	
Anode (engine)				○			Check/Replace if necessary.	
Anode (except for engine)			●/○				Check/Replace if necessary.	
Top cowl/Ratch					●/○		Check and adjust.	

\*"●" This procedure can be performed by end user.

\*"○" This procedure shall be carried out by the dealer.

ENON00030-1

## Note

It is highly recommended that your outboard motor to go through complete inspection at 300 hours of use.

ENOM00091-A

**Engine oil replacement**

ENOW00091-1

**⚠ CAUTION**

You may be injured due to high engine temperatures if you fill engine oil just after operation. Engine oil should be changed after the engine has been cooled.

ENOW00092-1

**⚠ CAUTION**

- Do not overfill engine oil, or engine oil could leak and/or engine could be damaged. If engine oil level is over upper limit marks of dip stick, drain oil to level lower than upper limit.
- Be sure that outboard motor is upright when checking or changing oil.
- Stop the engine immediately if low oil pressure warning lamp or oil leak is found, or engine could be severely damaged. Consult your dealer.
- Wipe off engine oil well immediately if spilled and dispose of it in accordance with local fire prevention and environment protection regulations.

ENOW00090-0

**⚠ CAUTION**

Use of engine oils that does not meet these requirements will result in reducing engine life, and other engine problems.

ENOW00933-0

**⚠ CAUTION**

Engine oil mixed with dust or water will dramatically shorten the life of the engine.

ENOM01906-0

**To change engine oil:**

Be sure to use recommended engine oil.

1. Stop the engine and leave it in a vertical position over 5 minutes.
2. Put an oil drain pan under the oil drain bolt.
3. Remove the oil drain bolt and completely drain oil from the engine.

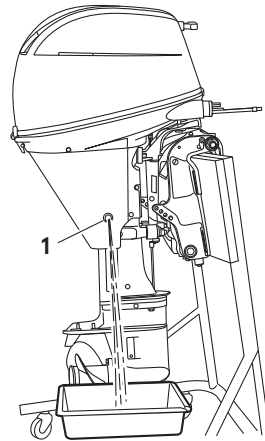

ENOF02552-0

1. Drain hole
4. Apply oil on the sealing surface of the drain bolt. Tighten the bolt with a new gasket.

Oil drain screw specified torque  
**24 N·m (17 ft·lb, 2.4 kgf·m)**

ENON00028-A

**Note**

If a torque-wrench is not available when you are fitting a oil filter, a good estimate of the correct torque is 3/4 to 1 a turn past finger-tight. Have the oil filter adjusted to the correct torque as soon as possible with a torque-wrench.

5. Pull the bottom of cowl latch to unlock, lift and remove the top cowl.

6. Fill the engine through the filler port with the recommended trapped oil to between the upper and lower limit mark on the dipstick.
7. Tighten the oil filler cap.
8. Leave the outboard motor for 5 minutes and check oil level on the dipstick. Add oil if necessary.
9. Insert the dipstick to the hole completely and install the top cowl.
10. Start the engine and idling for 5 minutes, then check for no oil leaks and no warning indicate.

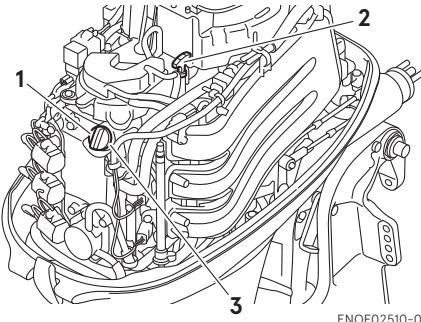

ENOF02510-0

1. Filler cap
2. Dipstick
3. Filler port

10



ENOF02511-0

1. Upper limit
2. Lower limit

ENON00920-0

**Note**

Use only recommended engine oil (See page 33)

Oil volume needed for complete oil replacement	
With oil filter replacement	Without oil filter replacement
Approximately 1700 mL (1.8/1.5 US/Imp. qt.)	Approximately 1500 mL (1.6/1.3 US/Imp. qt.)

ENOW00925-0

**CAUTION**

**Wipe off engine oil well immediately if spilled and dispose of it in accordance with local fire prevention and environment protection regulations.**

ENON00031-0

**Notes**

- If any amount of water is found in engine oil, making it milky white, consult dealer.
- If engine oil is contaminated with fuel, emitting strong fuel smell, consult dealer.
- Some oil dilution is normal if engine is idled or trolled for long periods, especially in cooler water temperatures.

ENOM01901-0

**Oil filter replacement**

ENOW00091-1

**CAUTION**

You may be injured due to high engine temperatures if you fill engine oil just after operation. Engine oil should be changed after the engine has been cooled.

ENOW00926-0

**CAUTION**

Wipe off engine oil well immediately if spilled and dispose of it in accordance with local fire prevention and environment protection regulations.

1. Drain oil from the engine.
2. Remove the yellow cap on the oil drip tray under the oil filter. Attach the hose to the nipple on the tray (hose inner diameter: 12.0 - 12.7 mm or 1/2 inch). Set the oil drain pan on the other side of the hose.
3. Unscrew old filter by turning the filter to counter-clockwise.
4. Clean the mounting base. Apply a film of clean oil to the O-ring on the new oil filter. Do not use grease.
5. Install oil filter and tighten it to specified torque by using oil filter wrench. Oil filter torque:  
**18 N·m (13 ft·lb, 1.8 kgf·m)**
6. Wipe up any spilled oil. Install the oil drip tray plug.

ENON00028-A

**Note**

If a torque-wrench is not available when you are fitting an oil filter, a good estimate of the correct torque is 3/4 to 1 a turn past finger-tight. Have the oil filter adjusted to the correct torque as soon as possible with a torque-wrench.

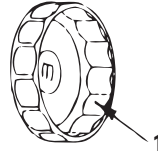

ENOF00094-0

1. Oil filter wrench  
P/N 3AC-99090-0  
P/N 3AC99090M  
(US. CANADA Only)

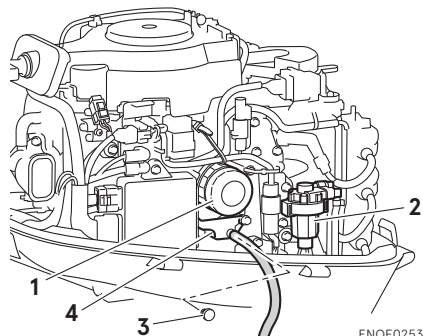

ENOF02533-0

1. Oil filter
2. Fuel filter
3. Oil drip tray plug
4. Oil drip tray

ENON00028-A

**Notes**

- The oil drip tray can be removed and cleaned with removing single bolt.
- By leaving few hours after the last operation, the amount of spilled oil will be reduced when removing the oil filter.

ENOM00093-A

### Fuel filters and fuel tank cleaning

ENOW00093-1



Gasoline and its vapor is very flammable and can be explosive.

- Do not start this procedure while engine is operating or while engine is hot.
- Place fuel filter away from every source of ignition such as sparks or open flames.
- If gasoline is spilled, wipe up immediately and dispose according to the local regulations.
- Install fuel filter with all related parts in place, or fuel leak could occur, leading to catching fire or explosion.
- Check fuel system regularly for leakage.
- Contact authorized dealer for fuel system services. Services by unqualified person could lead to engine damage.

Fuel filters are provided inside the fuel tank and engine.

ENOM00094-0

### Fuel filter (for engine)

1. Check the cup for water and debris.

#### ■ In case of water entry

1. Prepare a container under the outlet of the fuel filter.
2. Loosen the drain screw of the fuel filter.
3. Squeeze the primer bulb several times. After the water is drained, stop squeezing.
4. Tighten the drain screw securely and confirm there is no fuel leaking.

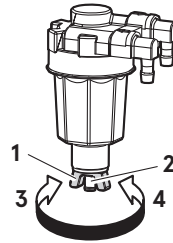

ENOF01242-1

1. Drain screw
2. Drain port
3. Loosen
4. Tighten

#### ■ In case of debris

1. If present, disconnect hoses from the fuel connector (male) and the fuel pump.
2. Remove the cup, filter and O-rings from the fuel filter body.
3. Check the wear and clogging for each parts, and replace if necessary.
4. Remove fuel and any water or debris from the cup, filter and hoses.
5. Reassemble all parts.

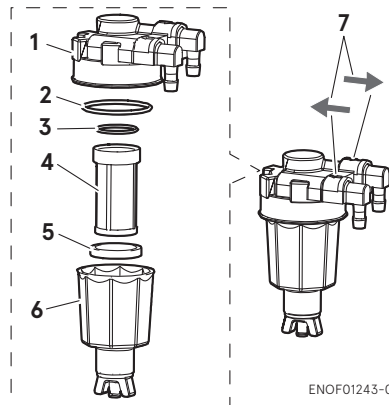

ENOF01243-0

1. Body
2. O-ring
3. O-ring
4. Filter
5. Float

6. Cup
7. Indicate of Fuel Flow

ENOM00096-A

### Fuel filter (for fuel tank)

Water or dirt in the fuel tank will cause engine performance problems.

Check and clean the tank at specified times or after the outboard motor has been stored for a long period of time (over three months).

1. Remove four screws to remove the Fuel Pick-Up.
2. Clean the fuel filter and replace the gasket.
3. Reassemble all parts.

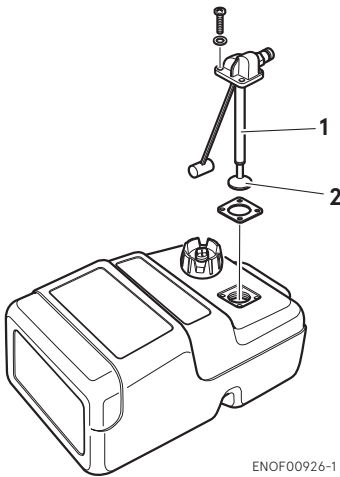

ENOF00926-1

1. Fuel pick-up
2. Filter

ENOM00098-A

### Gear oil replacement

ENOW00076-1

#### **! WARNING**

- Be sure that the outboard motor is secured to transom or service stand, or accidental drop or fall of outboard motor could lead to severe personal injury.
- Be sure to lock the outboard motor in the tilt up position, or accidental fall of outboard motor could lead to severe personal injury.
- Do not go under outboard motor in the tilt up position and locked, or accidental fall of outboard motor could lead to severe personal injury.

1. Tilt down the outboard motor.
2. Remove the oil plugs (lower and upper), and completely drain the gear oil into a pan.

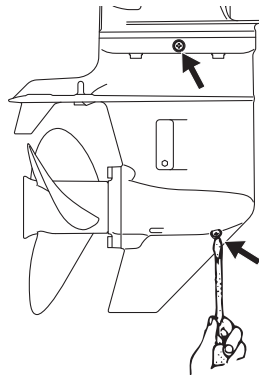

ENOF02534-0

3. Insert the oil tube nozzle into the lower oil plug hole, and fill with gear oil by squeezing the oil tube until oil flows out of the upper plug hole and bubbles is disappeared to remove the air.

ENON00033-1

**Note**

Use genuine gear oil or the ones recommended (API GL-5: SAE #80 to #90). Required volume: approx. 460 mL (15.6/16.2 US/Imp. oz.).

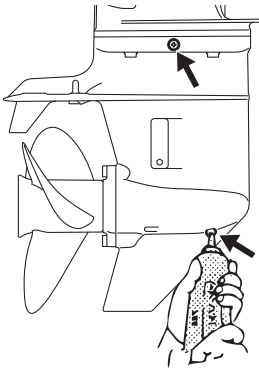

ENOF02535-0

4. Install the upper oil plug, and then remove oil tube nozzle and install the lower oil plug.

Oil plug specified tightening torque  
**4N·m (3 ft·lb, 0.4 kgf·m)**

ENOW00095-0

**CAUTION**

**Do not reuse oil plug gasket. Always use new gasket and tighten oil plug properly to prevent entry of water into lower unit.**

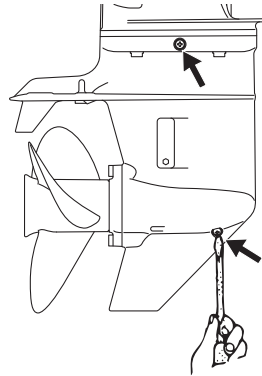

ENOF02534-0

ENOW00928-1

**CAUTION**

**If gear oil is spilled, wipe off immediately and dispose according to the local regulations.**

ENON00032-1

**Note**

If the gear oil color appears to be milky color, contact your dealer.



ENOM00086-A

**Propeller replacement**

ENOW00084-1

**WARNING**

- Do not install or remove propeller on the outboard motor with spark plug caps attached, shift in forward or reverse, main switch at other than "OFF", engine stop switch lock attached to the switch, and starter key attached, or engine could accidentally start leading to serious personal injury. Disconnecting battery cable is recommended (if equipped).
- The propeller edge is thin and sharp. Wear the gloves while installing or removing to protect your hands.

ENOW00086-1

**CAUTION**

- Do not install propeller without thrust holder, or propeller boss could be damaged.
- Do not reuse split pin.
- After installing split pin, spread bend both end of the pin apart to lock propeller in place.

A worn-out or bent propeller will lower the motor's performance, and cause engine trouble.

1. Put a piece of wood block between propeller blade and anti-ventilation plate to hold propeller.

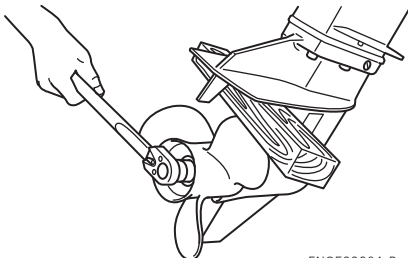

ENOF00084-B

2. Remove the split pin, propeller nut and washer.
3. Remove the propeller and thrust holder.
4. Apply waterproof grease to the propeller shaft before installing a new propeller.
5. Install the thrust holder, propeller, stopper, washer and propeller nut onto the shaft.

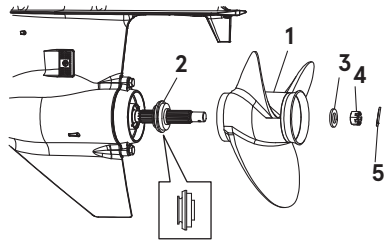

ENOF00084-C

1. Propeller
  2. Thrust holder
  3. Washer
  4. Propeller nut
  5. Split pin
6. Tighten the propeller nut to specified torque and align one of the grooves with propeller shaft hole.  
Propeller nut torque:  
**25 N·m (18 ft·lb, 2.5kgf·m)**
  7. Install a new split pin into the nut hole and bend both ends of pin apart to lock propeller in place.

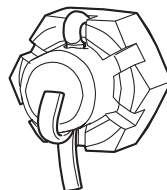

ENOF00084-E

ENOM00087-A

**Spark plugs replacement**

ENOW00087-1

**WARNING**

- Do not reuse spark plug, if the insulation is damaged or sparks can leak through crack, potentially leading to electric shock, explosion and/or fire.
- Do not touch spark plug(s) immediately after stopping engine as they will be hot and could cause severe burns if touched.

ENOW00929-0

**CAUTION**

Use only the recommended spark plugs. Spark plugs which have an different heat range may cause engine damage.

If the spark plug(s) is fouled, has carbon build up, or is worn, it should be replaced.

When reusing spark plugs, remove dirt from the electrodes and check the spark gap.

1. Stop the engine.
2. Remove the top cowl.
3. Remove the spark plug caps.
4. Remove the spark plugs by turning it counter-clockwise, using a 5/8" (16 mm) socket wrench and handle that are provided in the tool bag.
5. Inspect the spark plug. Replace the spark plug with wear on electrodes and if the insulators are cracked or chipped.
6. Measure the spark plug gap with a wire type feeler gauge. The gap should be 0.8-0.9 mm (0.031-0.035 inches). If the gap is out of specification, replace the spark plug with a new one.

Use spark plug NGK DCPR-6E.

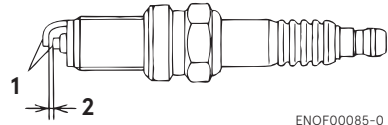

ENOF00085-0

1. Electrode
2. Spark gap (0.8-0.9 mm, 0.031-0.035 in)
7. Install the spark plug by hand and turn it carefully to avoid cross-threading.
8. Tighten the spark plug to the specified torque.

ENON00028-1

**Note**

- **Spark plug torque:**  
**18.0 N·m (13.3 ft·lb) [1.84 kgf·m]**

If a torque-wrench is not available when you are installing a spark plug, tighten it 1/4 to 1/2 a turn past finger-tight. Have the spark plug adjusted to the correct torque as soon as possible with a torque-wrench.

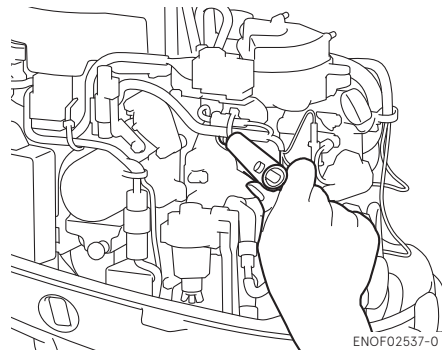

ENOF02537-0

ENOM00088-1A

## Anode replacement

A sacrificial anode protects the outboard motor from galvanic corrosion. Anode is located on the gear case, cylinder etc.. When the anode is eroded more than 1/3 of original size, replace it.

ENON00029-1

### Notes

- Never grease or paint the anode.
- At each inspection, re-tighten all the anode attaching bolts. Those bolts may loosen if the anodes are corroded.

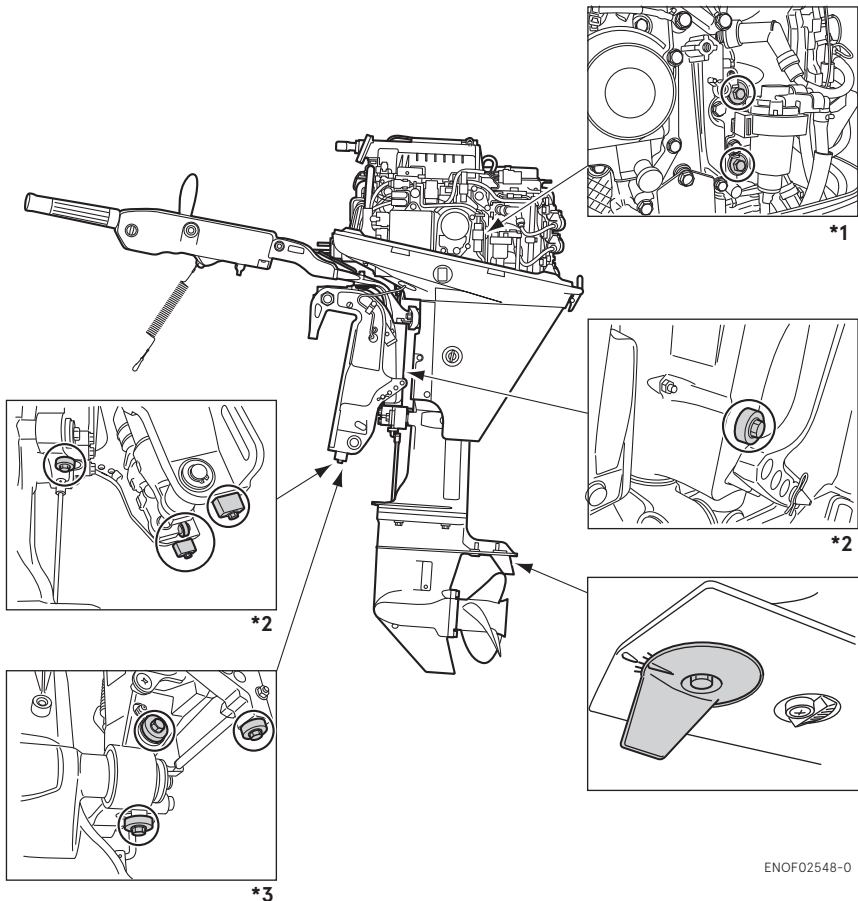

ENOF02548-0

\*1 : Remove fuel filter to access the anode.

\*2 : Power tilt model

\*3 : Manual tilt model

ENOM00089-B

### Power Tilt oil checking

ENOW00088-0

#### WARNING

- Be sure that outboard motor is secured to transom or service stand, or accidental drop or fall of outboard motor could lead to severe personal injury.
- Be sure to lock outboard motor if it is tilted up, or accidental fall of outboard motor could lead to severe personal injury.
- Do not go under outboard motor tilted up and locked, or accidental fall of outboard motor could lead to severe personal injury.

ENOW00089-A

#### CAUTION

Do not unscrew the oil cap with the outboard motor tilted down. Pressurized oil in the oil tank may spurt out.

Check the oil level in the reservoir tank while the tank is kept in a vertical position.

1. Tilt the outboard motor up and lock the tilt with the tilt stopper.
2. Remove the oil cap by turning counter-clockwise, then check if the oil level reaches the bottom line of the plug hole.

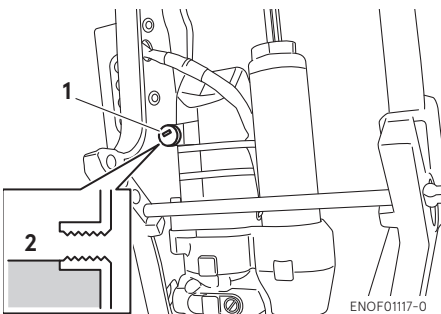

1. Oil cap
2. Oil level

### Recommended oil

Use automatic transmission fluid or equivalent.

Recommended oil is are as shown below.

### ATF Dexron III

### Air purging from the Power Trim and Tilt unit.

Trapped air in the Power Tilt unit will cause poor tilting movement and noise.

1. With the outboard motor installed on the boat, set the manual release valve to the Manual side, and tilt the outboard motor up/down manually 5-6 times.
2. When done, close the valve by turning it clockwise.

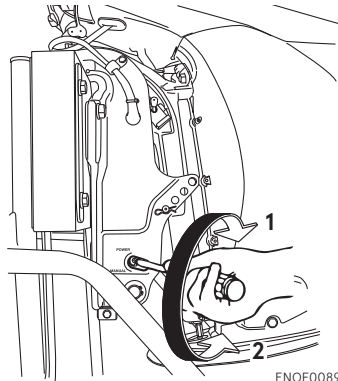

1. POWER
2. MANUAL

Manual relief valve specified tightening torque:

**2 N·m (1.5 ft·lb, 0.2 kgf·m)**

ENOM00960-0

**Grease point**

Apply waterproof grease to the parts shown below.

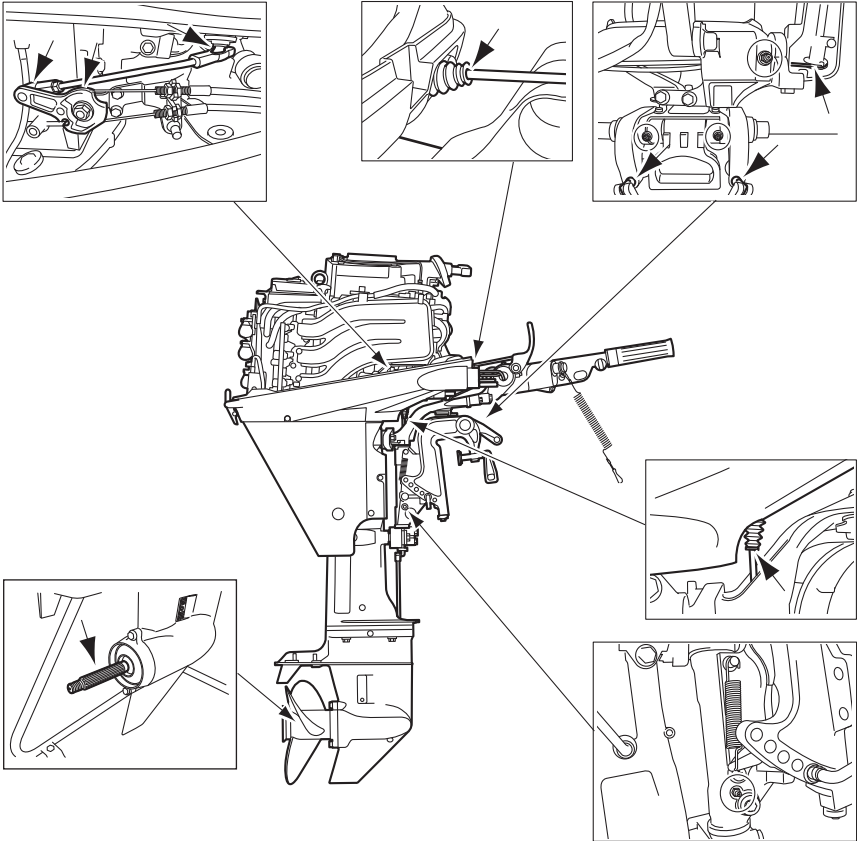

ENOF02549-0

ENOM00100-A

### 3. Off-season storage

ENOW00934-0

#### WARNING

- **Be sure to disconnect fuel connector except when operating engine.**
- **Fuel leakage is a fire or explosion hazard, which can cause serious injury or death.**

ENOW00097-0

#### WARNING

**Be sure to use cloth to remove fuel remaining in the cowl and dispose of it in accordance with local fire prevention and environment protection regulations.**

ENOW00096-0

#### CAUTION

**Before servicing the motor for storage:**

- **Remove the battery cables.**
- **Remove the spark plug caps from the spark plugs.**
- **Do not run the motor out of the water.**

Before you put your outboard motor in storage, it is a good opportunity to have it serviced by your dealer.

Be sure to use fuel stabilizer while running the motor before storage. (See page 87)

ENOM00101-1A

### Engine

1. Wash the engine exterior and flush the cooling water system thoroughly with fresh water. Drain the water completely.

Wipe off water with a cloth.

2. Remove the fuel hose from the outboard motor.
3. Drain all fuel from the fuel hoses, fuel pump, fuel filter (See page 78) and vapor separator (See page 88), and clean these parts.

Keep in mind that if gasoline is kept in the vapor separator for a long time, gum and varnish will be developed, causing the float valve to stick, restricting the fuel flow.

4. Remove the spark plugs and put a teaspoon of engine oil or spray storage oil into the combustion chamber through the spark plug holes.
5. Turn the starter motor several times to lubricate inside the cylinder. Remove the fuel hose from the outboard motor.

ENOW00930-1

#### WARNING

- **Be sure to remove stop switch lock to prevent the spark plugs from igniting.**
- **Put a cloth to spark plug hole and wipe up any spilled engine oil, when cranking the outboard motor.**

6. Change the engine oil (See page 75).
7. Change the gear oil in the gear case (See page 79).
8. Apply grease to grease point (See page 85).

9. Place the outboard motor in the vertical position under a dry condition.

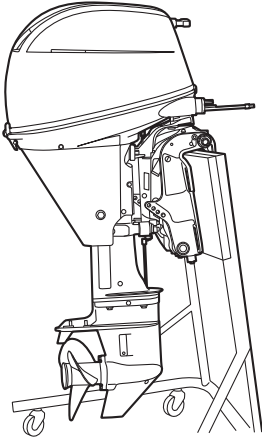

ENOF02528-0

ENOW00066-1

### ⚠ CAUTION

- Do not give a shock to an outboard motor during transportation.
- Do not carry or store outboard motor in any of positions described below.

Otherwise, engine's exterior may be damaged or water may enter the cylinder through the exhaust port and cause engine problems.

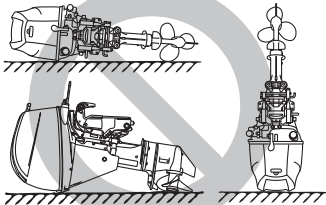

ENOF02527-0

ENON00021-3

### Note

If the outboard motor must be laid down, be sure that fuel is completely drained,

then lay the outboard motor with port side down on the cushion as shown in the drawing.

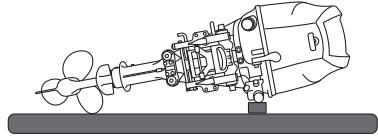

ENOF02529-0

ENOM00950-0

### Adding a fuel stabilizer

When adding a fuel stabilizer additive (commercially available), first fill the fuel tank with fresh fuel. If the fuel tank is only partially filled, air in the tank can cause the fuel to deteriorate during storage.

1. Before adding fuel stabilizer additive, drain the vapor separator (See page 88).
2. Follow the instructions on the label when adding the fuel stabilizer additive.
3. After adding the additive, let the outboard motor run in the water for 10 minutes to make sure any old fuel in the fuel system has been completely replaced by the fuel with additive.
4. Turn the engine OFF

ENON00891-1

### Note

If your motor is used occasionally, it is recommended to use a high quality fuel stabilizer for the fuel and keep the fuel tank full to reduce condensation and evaporation.

ENOM01902-0

**Fuel system draining**

ENOW00028-A

**WARNING**

For details on handling fuel, contact an authorized dealer.

Fuel and fuel vapors are extremely flammable and can be explosive.

- If fuel is spilled, wipe it up immediately.
- Keep the fuel tank well away from sources of ignition, e.g. sparks or open flames
- Perform all work outdoors or in a well ventilated place.

ENOW00097-0

**WARNING**

Be sure to use cloth to remove fuel remaining in the cowl and dispose of it in accordance with local fire prevention and environment protection regulations.

1. Disconnect the fuel hose from the outboard motor.
2. Remove the top cowl.
3. Remove the apron and cable cover stay.
4. Place an approved fuel container under the drain tube end and use a funnel to avoid spilling fuel.
5. Loosen the vapor separator drain screw.
6. When thoroughly drained, re-tighten the drain screw securely.

7. Check the drained fuel for the presence of water or other contaminants. If either is present, refill the vapor separator with fuel, and then drain the fuel again. Repeat this procedure until no water or other contaminants are present in the drained fuel.

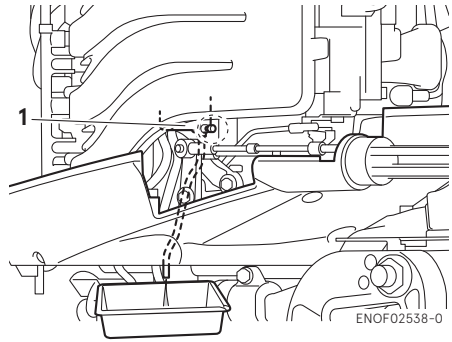

1. Vapor separator drain screw

ENOM00102-0

**Battery**

ENOW00931-A

**WARNING**

- Place the battery away from any source of fire, sparks and open flames such as burners or welding equipment.
- Place the battery away from fuel tank. Accidental sparks of battery may cause explosion of fuel.

1. Disconnect the battery cables and be sure to remove the negative terminal first.
2. Wipe off any chemical deposits, dirt, or grease.
3. Apply grease to the battery terminals.
4. Charge the battery completely before storing it for the winter.



5. Recharge the battery once a month to prevent it from discharging and the electrolyte from deteriorating.
6. Store the battery in a dry place.

ENOM00104-A

#### 4. Pre-season check

The following steps must be taken when first using the engine after off-season storage.

1. Check that the shift and throttle function properly. (Be sure to turn the propeller shaft when checking the shift function or else the shift linkage may be damaged.)
2. Check the electrolyte level, and measure the voltage and specific gravity of the battery.

Specific Gravity at 20°C	Terminal Voltage (V)	Charge Condition
1.120	10.5	Fully discharged
1.160	11.1	1/4 charged
1.210	11.7	1/2 charged
1.250	12	3/4 charged
1.280	13.2	Fully charged

3. Check that the battery is secure and the battery cables are properly installed.
4. Change the engine oil (See page 75).
5. Before starting the engine, disconnect stop switch lock and crank approximately 10 pulling the recoil starter (Manual start model) or 3times of 3sec. turning the starter motor (Electric start model) in order to prime the oil pump.
6. Fill fuel tank completely.

7. Start the engine and warm up the engine for 3 minutes in the "NEUTRAL" position.
8. Run the engine for 5 minutes at the slowest speed.
9. Run the engine for 10 minutes at half throttle. The oil used for storage inside the engine will be circulated out to assure optimum performance.

ENOM00105-A

#### 5. Submerged outboard motor

ENOW00098-0

### CAUTION

**Do not attempt to start submerged outboard motor immediately after it is recovered, or engine could be severely damaged.**

After taking your outboard motor out of the water, immediately take it to your dealer.

The following are the emergency measures to be taken for a submerged outboard motor.

1. Wash the outboard motor with fresh water to remove salt or dirt.
2. Remove the engine oil drain screw and completely drain water and oil from the engine.

3. Remove the spark plugs, and completely drain the water from the engine by pulling recoil starter several times.  
Replace oil filter and oil to the correct level.  
The oil and filter may need to be changed again after running a short period to get all moisture completely out of the crankcase.
4. Inject a sufficient amount of engine oil through the spark plug holes.  
Pull the recoil starter rope several times to circulate the oil throughout the outboard motor.

2. Check the control system, gear case, boat transom etc.
3. Return to the nearest harbor slowly and carefully.
4. Consult a dealer check the outboard motor before operation again.

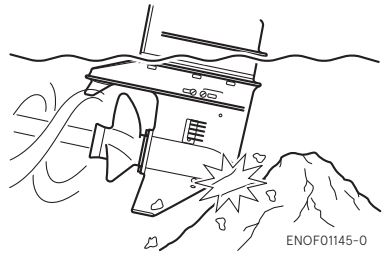

ENOM00106-1

## 6. Cold weather precautions

If you moor your boat in cold weather at temperatures below 0°C (32°F), water residue in water pump may freeze and may damage the pump, impeller, etc. To avoid, submerge the lower half of the outboard motor into the water.

ENOM00121-0

## 8. Operation with multiple outboard motors

When operating the outboard motors in reverse at more than the lowest speed, be sure that all engines are running. If any engine has stopped, be sure to tilt the outboard motor up and keep its propeller out of the water. Otherwise, water could enter the engine and cause damage to it.

10

ENOM00107-A

## 7. Striking underwater object

ENOW00935-0

**⚠ CAUTION**

**Striking the sea bottom or an underwater object may severely damage the outboard motor.**

Follow the procedure below and consult a dealer as soon as possible.

1. Stop the engine immediately.

# TROUBLESHOOTING

ENOM00109-0

If you encounter a problem, check the list below to determine the cause and to take the proper action.

An authorized dealer will always be happy to provide any assistance and information.

		Fuel and Lubrication Systems											Possible cause			
		Engine will not start.	Engine stalls immediately after starting	Defective idling	Poor acceleration	Engine speed is very high causing high speed ESG to operate.	Engine speed is very low, causing low speed ESG to operate.	Boat cannot run at high speed.	Engine overheats.	Battery is not charged.	Starter motor will not operate.	Power tilt will not operate.		Warning lamp "ON"	Warning lamp "Flash"	Warning buzzer "ON"
	●	●	●	●												Fuel level is low in the tank.
	●	●	●	●		●	●									Fuel system connection is incomplete.
	●	●	●	●		●	●									Fuel system sucks air.
	●	●	●	●		●	●									Fuel pipe is twisted.
	●	●	●	●		●	●									Fuel tank cap vent is closed
	●	●	●	●		●	●									Fuel filter, fuel pump or injector is clogged.
	●	●	●	●		●	●									Performance of fuel pump or vapor separator is deteriorated.
	●		●	●			●									Low quality fuel is used
			●	●			●									Primer bulb is clogged.
			●	●		●	●									Low quality engine oil is used.
			●	●												Engine oil quantity excessive (emissions of white smoke).
						●*							●*	●*		Engine oil is lacking (Oil pressure switch operates).
						●*							●*	●*		Oil pump is defective (Oil pressure switch operates).

\* Low speed ESG operates.

		Engine will not start.	Engine stalls immediately after starting	Defective idling	Poor acceleration	Engine speed is very high causing high speed ESG to operate.	Engine speed is very low, causing low speed ESG to operate.	Boat cannot run at high speed.	Engine overheats.	Battery is not charged.	Starter motor will not operate.	Power tilt will not operate.	Warning lamp "ON"	Warning lamp "Flash"	Warning buzzer "ON"	Possible cause
Electrical System	●	●	●	●	●		●*	●		●	●	●		●*	●*	Defective wiring, ground, wire disconnected or loosened.
	●	●	●	●	●		●	●								Use of spark plugs not specified.
	●	●	●	●	●		●	●								Spark plug is contaminated.
	●	●	●	●	●		●	●								No sparks or weak spark.
	●															Stop switch short-circuited.
	●															Stop switch lock is not installed correctly.
										●						Battery charging defective, or rectifier malfunctions.
		●									●	●	●			Battery is dead, connection is loose or corroded. Battery electrolyte level is low.
		●									●	●	●			Fuse is blown.
		●									●					Shift lever neutral (N) is not proper position.
												●				Start switch or main switch is defective.
											●					Starter motor or starter solenoid operation is defective.
												●				PTT switch or solenoid is defective.
												●				Air is mixed in PTT fluid.

\* Low speed ESG operates.

		Engine will not start.	Engine stalls immediately after starting	Defective idling	Poor acceleration	Engine speed is very high causing high speed ESG to operate.	Engine speed is very low, causing low speed ESG to operate.	Boat cannot run at high speed.	Engine overheats.	Battery is not charged.	Starter motor will not operate.	Power tilt will not operate.	Warning lamp "ON"	Warning lamp "Flash"	Warning buzzer "ON"	Possible cause	
Compression System	●															Low compression	
	●							●								Valve timing is not correct (Belt is stretched or installed incorrectly).	
	●							●								Valve clearance is defective.	
	●							●								Valve seat sealing is defective.	
	●							●								Piston, piston ring and/or cylinder is worn excessively.	
			●	●												Too much carbon deposition in the combustion chamber.	
	●								●							Spark plug tightening is loose.	
Others			●	●	●		●*	●	●				●*		●*	Cooling water is lacking (water pump is defective or clogged).	
			●	●	●		●*	●	●				●*		●*	Thermostat operation is defective.	
					●	●	●*	●	●				●*		●*	Anti-ventilation plate is damaged.	
					●	●	●	●	●				●		●	Mismatched propeller.	
					●	●	●	●	●				●		●	Propeller is damaged or deformed.	
					●	●	●	●	●				●		●	Thrust rod position is incorrect.	
					●		●	●								Boat is unbalanced by load position.	
				●		●	●	●	●				●		●	Transom installation height is too high or too low.	
				●			●	●								Improper throttle link adjustment.	

\* Low speed ESG operates.

# ACCESSORIES KIT

ENOM00109-0

The followings are a list of the tools and spare parts provided with the motor.

Items		Quantity	Remark	
Service tools	Tool bag	1	10 x 13 mm 16 mm (spark plug) Cross-and straight-point	
	Pliers	1		
	Socket wrench	1		
	Socket wrench	1		
	Socket wrench handle	1		
	Screwdrivers	1		
	Screwdriver handle	1		
Spare parts	Emergency starter rope	1	NGK: DCPR6E	
	Spark plug	1		
	Split pin	1		
	Stop switch lock	1		
Parts Packaged with Engine	Fuel tank	1	25 L	
	Primer bulb	1 set		
	Rigging bolt set			Manual tilt Model
	Bolt	2	M8 x 85 mm	
	Washer	4	M8	
	Nylon locking nut	2	M8	Power tilt Model
	Bolt	4	M12P1.25 x 105 mm	
	Washer	4	13-34-3	
	Washer	4	M12	
	Nylon locking nut	4	M12P1.25	E and ET Model
	Cable joint set			
	Cable joint	2		
	Washer	2	8.5-18-1.6	
	Snap pin	2		
Hose joint	1	For flushing		

## ■ PROPELLER TABLE

ENOM00111-0

Use a genuine propeller.

A propeller must be selected so that the engine RPM measured at wide open throttle while cruising is within the recommended range.

25 : 5000–6000 min<sup>-1</sup> (rpm)

30 : 5500–6500 min<sup>-1</sup> (rpm)

	Propeller Mark	Propeller Size (Diameter × pitch)	
		inch	mm
Light boats	14	9.9 × 14.2	252 × 360
	9.9 x 13	9.6 × 13	244 × 330
	9.9 x 12	9.8 × 12	249 × 305
	9.9 x 11	9.8 × 11	249 × 279
	9.9 x 10	9.72 × 10	247 × 254
	9.9 x 9	9.72 × 9	247 × 229
Heavy boats	F8 1/4	10.2 × 8.3	260 × 210

# OWNER'S MANUAL

MFS 25D  
MFS 30D

**TOHATSU CORPORATION**

5-4, Azusawa 3-Chome, Itabashi-Ku  
Tokyo 174-0051, Japan  
Tel: +81-3-3966-3117 Fax: +81-3-3966-0090  
[www.tohatsu.com](http://www.tohatsu.com)

